

# THERMOROSSI

## ARDHEA EVO5 – ARDHEA-F EVO5

ITA - MANUALE DI INSTALLAZIONE, USO E MANUTENZIONE.  
FRA - MANUEL D'INSTALLATION, D'UTILISATION ET D'ENTRETIEN.  
ENG - INSTALLATION, USE AND MAINTENANCE GUIDE.  
DEU - INSTALLATIONS-, BETRIEBS- UND WARTUNGSANLEITUNG.  
ESP - MANUAL DE INSTALACIÓN USO Y MANTENIMIENTO.



ITA – Informazioni importanti per la sicurezza ed il corretto funzionamento.  
FRA – À lire impérativement! Informations importantes pour la sécurité et le bon fonctionnement.  
ENG - Must read! Important information for safety and correct operation.  
DEU - Unbedingt lesen! Wichtige Informationen zur Sicherheit und zum sicheren Betrieb.  
ESP - ¡Leer! Informaciones importantes para la seguridad y el correcto funcionamiento.



**INDEX**

<b>1 – INTRODUCTION.....</b>	<b>5</b>
<b>2 – TECHNICAL CHARACTERISTICS.....</b>	<b>7</b>
<b>3 – GENERAL DESCRIPTION .....</b>	<b>9</b>
<b>4 – INSTALLATION.....</b>	<b>11</b>
<b>5 – PLUMBING SYSTEM CONNECTIONS AND DIAGRAMS .....</b>	<b>12</b>
<b>6 – ASSEMBLING THE COMPONENTS.....</b>	<b>16</b>
<b>7 – USE OF THE APPLIANCE .....</b>	<b>20</b>
<b>8 - CLEANING AND MAINTENANCE .....</b>	<b>23</b>
<b>9 - SMOKE DISCHARGE TUBE.....</b>	<b>25</b>
<b>10 - PROBLEMS, CAUSES AND SOLUTIONS.....</b>	<b>27</b>
<b>11 - SPARE PARTS .....</b>	<b>28</b>

**EU Declaration of Conformity (DoC) / Dichiarazione di Conformità UE (DoC)**

<b>Company name:</b> <b>Azienda:</b>	<b>THERMOROSSI S.P.A.</b>	<b>Postal address:</b> <b>Indirizzo:</b>	<b>VIA GRUMOLO, N° 4</b>
Postcode and city: Codice postale e città:	<b>36011 ARSIERO (VI)</b>	Telephone number: Numero di telefono:	<b>0445/741310</b>
E-mail address: Indirizzo e-mail:	<b>INFO@THERMOROSSI.IT</b>		

declare that the DoC is issued under our sole responsibility and belongs to the following product:  
dichiara che la dichiarazione viene rilasciata sotto la propria responsabilità e si riferisce al seguente prodotto:

<b>Apparatus model / Product:</b> <b>Descrizione prodotto:</b>	<b>WOOD STOVE</b> <b>STUFA A LEGNA</b>	<b>Trademark:</b> <b>Marchio:</b>	<b>THERMOROSSI S.P.A.</b>
<b>Models:</b> <b>Modelli:</b>	<b>ARDHEA EVO5</b> <b>ARDHEA-F EVO5</b>		

The object of the declaration described above is in conformity with the relevant Union harmonisation legislation:  
L'oggetto della dichiarazione di cui sopra è conforme alla pertinente normativa di armonizzazione dell'Unione:

- **Direttiva 2014/30/UE, EMCD**
- **Direttiva 2014/35/UE, LVD**
- **Direttiva 2011/65/UE, RoHS**
- **2014/30/EU Directive, EMCD**
- **2014/35/EU Directive, LVD**
- **2011/65/EU Directive, RoHS**

Sono state applicate le seguenti norme armonizzate e/o specifiche tecniche:

The following harmonised standards and/or technical specifications have been applied:

EN 55014-1	EN 60335-1	
EN 55014-2	EN 60335-2-102	EN 50581
EN 61000-3-2	EN 62233	
EN 61000-3-3		

EN 13240 tests carried out by the notified laboratory Kiwa Cermet Italia S.p.a (N.B. 0476) Viale Venezia, 45 31020 San Vendemiano (TV).

Arsiero, 15/07/2021

Firma/Sign.

  
THERMOROSSI S.P.A.  
Un Administrator

## Installation, use and maintenance guide

### ARDHEA EVO5 – ARDHEA-F EVO5

<b>THERMOROSSI</b> <i>Fire Lovers</i>		<b>DICHIARAZIONE DI PRESTAZIONE IN ACCORDO CON IL REGOLAMENTO (UE) 305/2011</b> <i>DECLARATION OF PERFORMANCE ACCORDING TO REGULATION (EU) 305/2011</i>		<b>N° 50</b>
1	Codice di identificazione unico del prodotto-tipo: <b>ARDHEA EVO5</b> <i>Unique identification code of the product type:</i>	2	Modello, lotto, serie ai sensi dell'articolo 11, paragrafo 4: <b>ARDHEA EVO5</b> <i>Model, batch or serial number required under Article 11(4):</i>	
3	Usi previsti del prodotto da costruzione, conformemente alla relativa specifica tecnica armonizzata: <i>Intended uses of the construction product, in accordance with the applicable harmonised technical specification:</i> <b>Apparecchio per il riscaldamento domestico, con acqua, alimentato a ceppi di legna / Residential space heating appliance with water fired by wood logs</b>			
4	Nome registrato e indirizzo del fabbricante ai sensi dell'articolo 11, paragrafo 5: <i>Name and contact address of the manufacturer as required pursuant to Article 11 (5):</i> <b>THERMOROSSI S.P.A. Via Grumolo, n° 4 36011 Arsiero (Vicenza)</b>	5	Nome e indirizzo del mandatario ai sensi dell'articolo 12, paragrafo 2: <i>Name and address of the agent as required pursuant to Article 12 (2):</i> -	
6	Sistema di valutazione e verifica della costanza della prestazione del prodotto da costruzione di cui all'allegato V: <b>Sistema 3</b> <i>System of assessment and verification of constancy of performance of the construction product as set out in Annex V: System 3</i>			
7	Laboratorio notificato: <i>Notified laboratory:</i> <b>KIWA CERMET ITALIA S.p.A. N° 0476</b>	Numero del rapporto di prova secondo il sistema 3 / Test report number based on System 3: <b>2005121</b>		
<b>Prestazione dichiarata / Declared performance</b>				
<i>Specifica tecnica armonizzata / Harmonized technical specification:</i>		<b>EN 13240:2001</b>		
<i>Caratteristiche Essenziali / Essential characteristics</i>		<b>Prestazione / Performance</b>		
<i>Reazione al fuoco / Reaction to fire</i>		<b>A1</b>		
<i>Distanza da materiali combustibili / Distance to combustible materials</i>		Minime distanze / <i>Minimum distances</i> (mm): posteriore/rear = <b>300</b> lati/sides = <b>300</b> frontale / front = <b>800</b> soffitto/ceiling = - pavimento / floor = -		
<i>Rischio di fuoriuscita di braci incandescenti / Risk of burning fuel falling out</i>		<b>Conforme / Compliant</b>		
<i>Temperatura superficiale / Surface temperature</i>		<b>Conforme / Compliant</b>		
8	<i>Sicurezza elettrica / Electrical safety</i>		-	
<i>Pulizia / Cleanability</i>		<b>Conforme / Compliant</b>		
<i>Emissione di prodotti della combustione / Emission of combustion products</i>		<b>CO = 79 mg/m<sup>3</sup></b> a potenza termica nominale / <i>CO at Nominal heat output</i>		
<i>Pressione massima di esercizio / Maximum operating pressure</i>		<b>2.5 bar</b>		
<i>Temperatura fumi a potenza termica nominale / Flue gas temperature at nominal heat output</i>		<b>T 153 °C</b>		
<i>Resistenza meccanica (per sopportare il camino) / Mechanical resistance (to carry a chimney)</i>		<b>NPD {No Determined Performance}</b>		
<i>Potenza termica nominale / Nominal heat output</i>		<b>15.10 kW</b>		
<i>Potenza termica resa in ambiente / Room heating output</i>		<b>4.10 kW</b>		
<i>Potenza termica ceduta all'acqua / Water heating output</i>		<b>11.00 kW</b>		
<i>Rendimento / Efficiency</i>		<b>92.20 %</b> Alla potenza termica nominale / <i>Nominal heat output</i>		
9	La prestazione del prodotto di cui ai punti 1 e 2 è conforme alla prestazione dichiarata di cui al punto 8. Si rilascia la presente dichiarazione di prestazione sotto la responsabilità esclusiva del fabbricante di cui al punto 4. <i>The performance of the product identified in points 1 and 2 is in conformity with the declared performance in point 8.</i> <i>This declaration of performance is issued under the sole responsibility of the manufacturer identified in point 4.</i> Arsiero, 15/07/2021			
				<i>Firma/Signature:</i> 

<b>THERMOROSSI</b> <i>Fire Lovers</i>		<b>DICHIARAZIONE DI PRESTAZIONE IN ACCORDO CON IL REGOLAMENTO (UE) 305/2011</b> <i>DECLARATION OF PERFORMANCE ACCORDING TO REGULATION (EU) 305/2011</i>		<b>N° 51</b>
1	Codice di identificazione unico del prodotto-tipo: <b>ARDHEA-F EVO5</b> <i>Unique identification code of the product type:</i>	2	Modello, lotto, serie ai sensi dell'articolo 11, paragrafo 4: <b>ARDHEA-F EVO5</b> <i>Model, batch or serial number required under Article 11(4):</i>	
3	Usi previsti del prodotto da costruzione, conformemente alla relativa specifica tecnica armonizzata: <i>Intended uses of the construction product, in accordance with the applicable harmonised technical specification:</i> <b>Apparecchio per il riscaldamento domestico, con acqua, alimentato a ceppi di legna / Residential space heating appliance with water fired by wood logs</b>			
4	Nome registrato e indirizzo del fabbricante ai sensi dell'articolo 11, paragrafo 5: <i>Name and contact address of the manufacturer as required pursuant to Article 11 (5):</i> <b>THERMOROSSI S.P.A. Via Grumolo, n° 4 36011 Arsiero (Vicenza)</b>	5	Nome e indirizzo del mandatario ai sensi dell'articolo 12, paragrafo 2: <i>Name and address of the agent as required pursuant to Article 12 (2):</i> -	
6	Sistema di valutazione e verifica della costanza della prestazione del prodotto da costruzione di cui all'allegato V: <b>Sistema 3</b> <i>System of assessment and verification of constancy of performance of the construction product as set out in Annex V: System 3</i>			
7	Laboratorio notificato: <i>Notified laboratory:</i> <b>KIWA CERMET ITALIA S.p.A. N° 0476</b>	Numero del rapporto di prova secondo il sistema 3 / Test report number based on System 3: <b>2005121</b>		
<b>Prestazione dichiarata / Declared performance</b>				
<i>Specifica tecnica armonizzata / Harmonized technical specification:</i>		<b>EN 13240:2001</b>		
<i>Caratteristiche Essenziali / Essential characteristics</i>		<b>Prestazione / Performance</b>		
<i>Reazione al fuoco / Reaction to fire</i>		<b>A1</b>		
<i>Distanza da materiali combustibili / Distance to combustible materials</i>		Minime distanze / <i>Minimum distances</i> (mm): posteriore/rear = <b>300</b> lati/sides = <b>300</b> frontale / front = <b>800</b> soffitto/ceiling = - pavimento / floor = -		
<i>Rischio di fuoriuscita di braci incandescenti / Risk of burning fuel falling out</i>		<b>Conforme / Compliant</b>		
<i>Temperatura superficiale / Surface temperature</i>		<b>Conforme / Compliant</b>		
8	<i>Sicurezza elettrica / Electrical safety</i>		-	
<i>Pulizia / Cleanability</i>		<b>Conforme / Compliant</b>		
<i>Emissione di prodotti della combustione / Emission of combustion products</i>		<b>CO = 79 mg/m<sup>3</sup></b> a potenza termica nominale / <i>CO at Nominal heat output</i>		
<i>Pressione massima di esercizio / Maximum operating pressure</i>		<b>2.5 bar</b>		
<i>Temperatura fumi a potenza termica nominale / Flue gas temperature at nominal heat output</i>		<b>T 153 °C</b>		
<i>Resistenza meccanica (per sopportare il camino) / Mechanical resistance (to carry a chimney)</i>		<b>NPD {No Determined Performance}</b>		
<i>Potenza termica nominale / Nominal heat output</i>		<b>15.10 kW</b>		
<i>Potenza termica resa in ambiente / Room heating output</i>		<b>4.10 kW</b>		
<i>Potenza termica ceduta all'acqua / Water heating output</i>		<b>11.00 kW</b>		
<i>Rendimento / Efficiency</i>		<b>92.20 %</b> alla potenza termica nominale / <i>Nominal heat output</i>		
9	La prestazione del prodotto di cui ai punti 1 e 2 è conforme alla prestazione dichiarata di cui al punto 8. Si rilascia la presente dichiarazione di prestazione sotto la responsabilità esclusiva del fabbricante di cui al punto 4. <i>The performance of the product identified in points 1 and 2 is in conformity with the declared performance in point 8.</i> <i>This declaration of performance is issued under the sole responsibility of the manufacturer identified in point 4.</i> Arsiero, 15/07/2021			
				<i>Firma/Signature:</i> 

IT – SCHEDA PRODOTTO (UE 2015/1186) EN – PRODUCT FICHE (EU 2015/1186) FR – FICHE PRODUIT (UE 2015/1186) NL – PRODUCTGEGEVENSBLAD (EU 2015/1186) DE – PRODUKTDATENBLATT (EU 2015/1186) ES – FICHA DE PRODUCTO (UE 2015/1186)	IT – MARCHIO EN – BRAND FR – MARQUE NL – MERK DE – MARKE ES – MARCA	<b>THERMOROSSI S.P.A.</b>	
IT – MODELLO EN – MODEL FR – MODÈLE NL – MODEL DE – MODELL ES – MODELO		<b>ARDHEA EVO5</b>	<b>ARDHEA-F EVO5</b>
IT – CLASSE DI EFFICIENZA ENERGETICA EN – ENERGY EFFICIENCY CLASS FR – CLASSE D'EFFICACITÉ ÉNERGÉTIQUE NL – ENERGIE EFFICIENTIEKLASSE DE – ENERGIEEFFIZIENZKLASSE ES – CLASE DE EFICIENCIA ENERGÉTICA		<b>A +</b>	<b>A +</b>
IT – POTENZA TERMICA DIRETTA EN – DIRECT HEAT OUTPUT FR – PUISSANCE THERMIQUE DIRECTE NL – DIREKTE WARMTEAFGIFTE DE – DIREKTE WÄRMELEISTUNG ES – POTENCIA CALORÍFICA DIRECTA		<b>4,1 kW</b>	<b>4,1 kW</b>
IT – POTENZA TERMICA INDIRETTA EN – INDIRECT HEAT OUTPUT FR – PUISSANCE THERMIQUE INDIRECTE NL – INDIRECTE WARMTEAFGIFTE DE – INDIRECTE WÄRMELEISTUNG ES – POTENCIA CALORÍFICA INDIRECTA		<b>11,0 kW</b>	<b>11,0 kW</b>
IT – INDICE DI EFFICIENZA ENERGETICA EN – ENERGY EFFICIENCY INDEX FR – INDICE D'EFFICACITÉ ÉNERGÉTIQUE NL – ENERGIE-EFFICIENTIE-INDEX DE – ENERGIEEFFIZIENZINDEX ES – ÍNDICE DE EFICIENCIA ENERGÉTICA		<b>124</b>	<b>124</b>
IT – EFFICIENZA UTILE ALLA POTENZA TERMICA NOMINALE EN – USEFUL ENERGY EFFICIENCY AT NOMINAL HEAT OUTPUT FR – RENDEMENT UTILE À LA PUISSANCE THERMIQUE NOMINALE NL – NUTTIG RENDEMENT BIJ NOMINAAL VERMOGEN DE – BRENNSTOFF-ENERGIEEFFIZIENZ BEI NENNWÄRMELEISTUNG ES – EFICIENCIA ENERGÉTICA ÚTIL A POTENCIA CALORÍFICA NOMINAL		<b>92,2%</b>	<b>92,2%</b>
IT – EFFICIENZA UTILE AL CARICO MINIMO EN – USEFUL ENERGY EFFICIENCY AT MINIMUM LOAD FR – RENDEMENT UTILE À LA CHARGE MINIMALE NL – NUTTIG RENDEMENT BIJ MINIMALE WARMTEAFGIFTE DE – BRENNSTOFF-ENERGIEEFFIZIENZ BEI MINDESTLAST ES – EFICIENCIA ENERGÉTICA ÚTIL A CARGA MINIMA		<b>-</b>	<b>-</b>
IT – RISPETTARE TUTTE LE ISTRUZIONI RIPORTATE SUL MANUALE DI INSTALLAZIONE USO E MANUTENZIONE EN – ALWAYS FOLLOW THE INSTRUCTIONS PROVIDED IN THE OPERATING AND MAINTENANCE MANUAL FR – RESPECTER TOUTES LES INSTRUCTIONS CITÉES DANS LA NOTICE D'INSTALLATION, UTILISATION ET ENTRETIEN NL – VOLG ALTIJD DE INSTRUCTIES VAN DE INSTALLATIE-, GERUÏKERSHANDLEIDING EN DE ONDERHOUDSVOORSCHRIFTEN DE – ERFÜLLEN DIE ANWEISUNGEN DER INSTALLATION, NUTZUNG UND WARTUNG, DIE IN DER ANLEITUNGSBUCH SIND ES – RESPECTAR LAS INSTRUCCIONES REPORTADAS EN EL MANUAL DE UTILIZACIÓN Y MANTENIMIENTO			

### THERMOROSSI S.P.A.

certifies compliance with the requirements specified in *Decree no. 186 of 7 November 2017:*

*“Regulation establishing the requirements, procedures and responsibilities for the issuing of certification for heat generators powered by solid biomass fuel”:*

With the following Environmental Classification:		
<b>ARDHEA EVO5</b>	<b>★ ★ ★ ★ ★</b>	<b>(5 STARS)</b>
<b>ARDHEA-F EVO5</b>	<b>★ ★ ★ ★ ★</b>	<b>(5 STARS)</b>

Arsiero, 15/07/2021

Signature:  
  
THERMOROSSI S.P.A.  
Un Administrator

## 1 – INTRODUCTION

### 1.1 SAFETY GUIDELINES

This installation, use and maintenance manual is an integral and essential part of the product and must be kept by the user. Before commencing with the installation, use and maintenance of the product, carefully read this guide. All local, national and European regulations regarding the installation and use of the appliance must be met. The Manufacturer recommends carrying out all the maintenance operations described in this manual.

This appliance must only be used as intended by the manufacturer. Any other use is considered incorrect and therefore hazardous; consequently, the user shall be totally liable for the product if used improperly. Installation, maintenance and repairs must be carried out by professionally qualified personnel, certified according to Decree no. 37 of 22 January 2008 and in compliance with current regulations. In case of repairs only original spare parts supplied by the manufacturer must be used. Incorrect installation or poor maintenance can injure or damage people, animals or things; in this case the manufacturer shall be relieved of all responsibility. Any repairs or actions carried out on any systems, components or internal parts of the appliance, or on any of the accessories supplied with it, that are not specifically authorised by Thermorossi S.p.A, will automatically void the warranty and the manufacturer's responsibility, pursuant to Italian Decree no. 224 of the President of the Republic of 24/05/1988, art. 6/b. It is recommended to keep this manual in a safe place that is easily accessible to all users. If the manual is lost or deteriorated contact the manufacturer for a replacement copy. If the appliance is sold or transferred to another user ensure that the manual is handed over with it. The images and figures featured in this manual are purely illustrative and may differ from the actual product. Furthermore, Thermorossi reserves the right to apply changes to the content of this manual anytime and without notice.

*Thermorossi S.p.A. retains copyright on this manual. These instructions may not be reproduced or communicated to third parties or used in any other way without the necessary authorisation.*

### 1.2 SAFETY STANDARDS



#### PERSONAL INJURY

This safety symbol identifies important messages throughout the manual. Read the information marked by this symbol carefully as non-observance of this message can cause serious injury to persons using the appliance.



#### DAMAGE TO PROPERTY

This safety symbol identifies messages or instructions that are fundamental for the appliance and system to function well. To avoid serious damage to the appliance adhere strictly to these instructions.



#### INFORMATION

This symbol indicates important instructions for good functioning of the appliance. If this information is not correctly observed, the performance of the appliance will not be satisfactory.

### 1.3 RECOMMENDATIONS



Read this entire use and maintenance manual carefully before using the appliance as familiarity with the information and instructions contained in it are essential for the correct use of the appliance.

No responsibility will be accepted for damages, even to third parties, if the instructions for installation, use and maintenance of the appliance are not followed scrupulously. Modifications made to the appliance by the user or on his behalf, must be considered to be under his complete responsibility. The user is responsible for all the operations required for the maintenance of the appliance before and during its use.



Should you notice an excessive stagnation of flue gas in the combustion chamber, move away from the appliance immediately. In particular move away from the glass door of the combustion chamber. The excessive concentration of unburned gases could create an explosion that could break the glass. Do not open the loading door for any reason whatsoever and do not approach the product until the flame has died down. Contact a technical service centre to determine the causes. Do not turn on the appliance for any reason whatsoever following an event such as this.

### 1.4 GENERAL GUIDELINES



Attention: the appliance must be connected to a system provided with a PE conductor (in compliance with the specifications concerning low-voltage equipment). Before installing the appliance check the efficiency of the earth circuit of the power supply system.

Attention: the cable section must in any case be no less than 1.5 mm<sup>2</sup>. The appliance requires powering with a voltage of 230 V and 50 Hz. Position the appliance so that the electric power outlet in the room is easily accessible. Ensure that a suitable differential switch is installed upstream from the equipment.

The product must not be used by children under the age of 8 years, by persons with physical, mental or sensorial impairments, or by persons who are not familiar with the instructions for use and maintenance of the product (the instructions are found in this booklet). Children must not play with the appliance.

ATTENTION: before each use make sure that the grate and the ash pan are perfectly clean and check that the firebox door is firmly closed and airtight.

ATTENTION: it is strictly forbidden to open the door while the flame is still burning. During operation, the smoke exhaust pipes, door, handles and some parts of the appliance may reach extremely high temperatures: be careful not to touch them and also

**ARDHEA EVO5 – ARDHEA-F EVO5**

educate children to be aware of said risks. Do not expose your body to hot air for long, do not overheat the room in which the appliance is installed, as these actions could cause health problems. Do not expose plants or animals directly to the hot air flow as this could have noxious effects on them. It is prohibited to use any liquids or gases such as alcohol, petrol, etc. to light or rekindle the fire, use only thin wood. Do not place non-heat resistant or inflammable or combustible objects in the vicinity of the appliance: keep them at a suitable distance. Do not place wet clothing to dry on the appliance. When using a clothes horse, keep at a suitable distance. It is strictly prohibited to disconnect the appliance from the electrical power mains while it is in operation.



Caution: do not wet the appliance and do not touch the electrical parts with wet hands. Never vacuum hot ash: this could damage the vacuum device. All the cleaning operations described in this manual must be carried out when the appliance is cold and shut off.



Attention! Warning for Swiss users

Refer to the local cantonal regulations imposed by the Fire Department (Mandatory signalling and safety distances) and the Note concerning installation of heaters issued by the Association of Cantonal Fire Agencies (VKF - AEAI).



ATTENTION: it is mandatory to earth the appliance. If this instruction is not observed serious damage, which is not covered by warranty, will result to the body of the appliance. Have an electrician check the earthing. There must be no electric potential (Volt) between the earth of the generator and the actual earth of the system.

**1.5 TRANSPORTATION AND STORAGE**

**TRANSPORTATION AND HANDLING**

The appliance body must always be handled exclusively by means of trolleys. Take special care to protect the glass and all the fragile parts from mechanical impact which could damage them and their correct functioning.

**STORAGE**

The appliance must be stored in a humid-free environment and sheltered from the weather; avoid placing the appliance directly on the ground. The Company denies all responsibility for damage caused to wood floors or floors made from any other material. It is inadvisable to store the product for long periods of time.

**1.6 GUIDELINES FOR CORRECT DISPOSAL OF THE PRODUCT**



At the end of the product's useful life, it must be disposed of in compliance with applicable regulations and in respect of the environment, not with urban waste. The product must be consigned to designated sorted waste collection centres for the disposal of waste authorised by the local municipal councils. Correct disposal not only helps safeguard the environment but it also promotes recovery and recycling of the materials.

**2 – TECHNICAL CHARACTERISTICS**

	<b>ARDHEA EVO5</b>	<b>ARDHEA-F EVO5</b>
Height (mm)	1,171	1,533
Depth (mm)	642	642
Width (mm)	592	592
Empty weight without casing (kg)	215	258
Ø Internal smoke outlet (mm)	150	150
Ø External smoke outlet (mm)	154	154
Minimum draught (Pa)	14	14
Maximum permitted fuel feed kg ***	4.6	4.6
Maximum hourly consumption (kg/h) ***	3.8	3.8
Average load duration (Min) **	50	50
Firebox power (kW) **	16.4	16.4
Rated power (kW) **	15.1	15.1
Output to water (kW) **	11.0	11.0
Output to the room (kW) **	4.1	4.1
Efficiency (%) **	92.2	92.2
CO emissions (mg/m <sup>3</sup> at 13% O <sub>2</sub> ) **	79	79
Heatable volume (m <sup>3</sup> ) *	400	400
Average smoke temperature (°C) **	153	153
Smoke flow rate (g/s) **	8.2	8.2
Water content (l)	33	33
Minimum working pressure	1.0	1.0
Maximum working pressure	2.5	2.5
Max delivery water temperature (°C)	80	80
Min water return temperature (°C)	55	55
Firebox feed opening dimensions (mm) (LxH)	306x316	306x316
Firebox dimensions (mm) (LxHxD)	424x430x355	424x430x355
Oven dimensions (mm) (LxHxD)	-	340x277x390
Power supply voltage and frequency (V – Hz)	230 – 50	230 – 50

**\*\* IMPORTANT:** It is important to take into consideration the fact that the heatable volume is greatly influenced by the insulation of the house (energy class of the building) and by the position of the appliance in the planimetry of the house, therefore the indicated values may vary, even significantly.

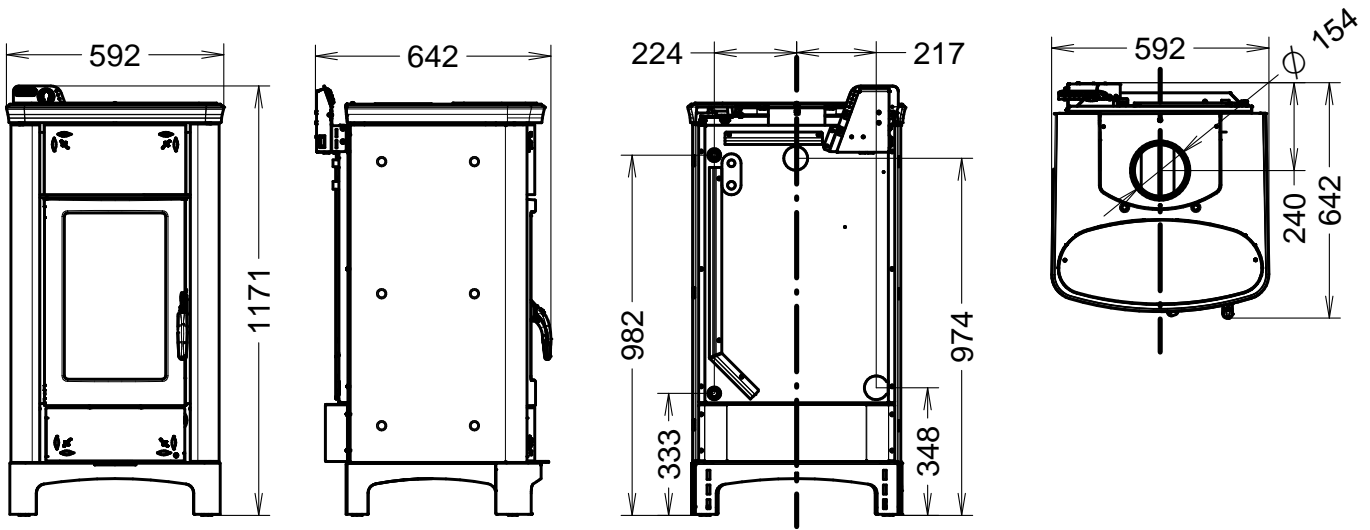
**\*\* ATTENTION:** The indicated values were obtained using beechwood logs (3 logs) with thermal value less than or equal to 15,429 kJ/kg and moisture content less than 15%. The use of poorer quality firewood than that specified results in lower yield and lower efficiency, and produces more ash. Moreover the glass on the feed door will become dirtier sooner.

**\*\*\*** It is strictly prohibited to load a greater quantity of fuel than that specified in the table. The warranty will not cover damages caused by the prolonged exposure of the appliance to temperatures that are too high.

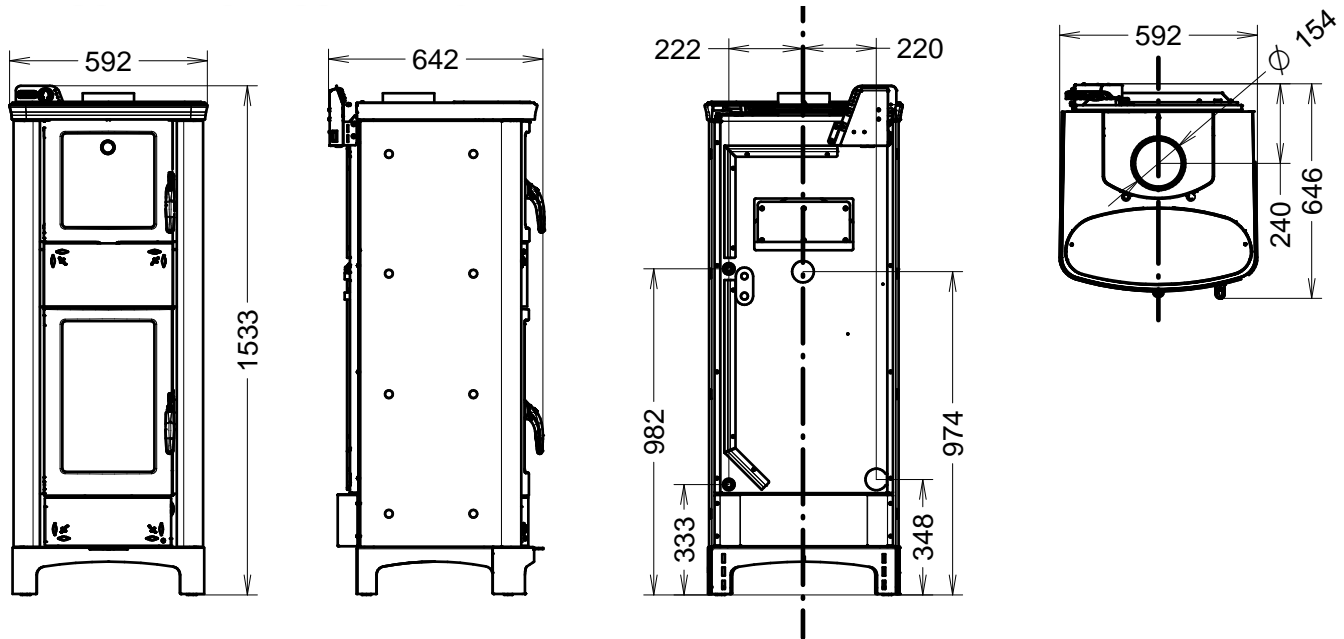


**2.1 DIMENSIONS**

**ARDHEA EVO5**



**ARDHEA-F EVO5**



**3 – GENERAL DESCRIPTION**

**3.1 THE FUEL**

The fuel for this appliance is ordinary wood billets with a moisture content between 10% and 20% and with a thermal value of 13,000 to 15,429 Kcal/kg. We recommend using beech or common hornbeam. If using wood with a lower moisture content or with a higher thermal value, the heat produced by the stove will be greater.

The awareness and use of the right fuel are important aspects to be observed in order to ensure correct operation and long service life of the appliance. To this end we recommend using only dry, well-seasoned wood. We recommend against using wet wood or wood that has been seasoned for less than 18/20 months, as this could be the cause of malfunctions and the formation of tarry deposits that could permanently blacken the walls of the combustion chamber.

We recommend using logs with a length of 250 mm (max recommended section Ø 80 mm) and loading a maximum of 3-4 logs.

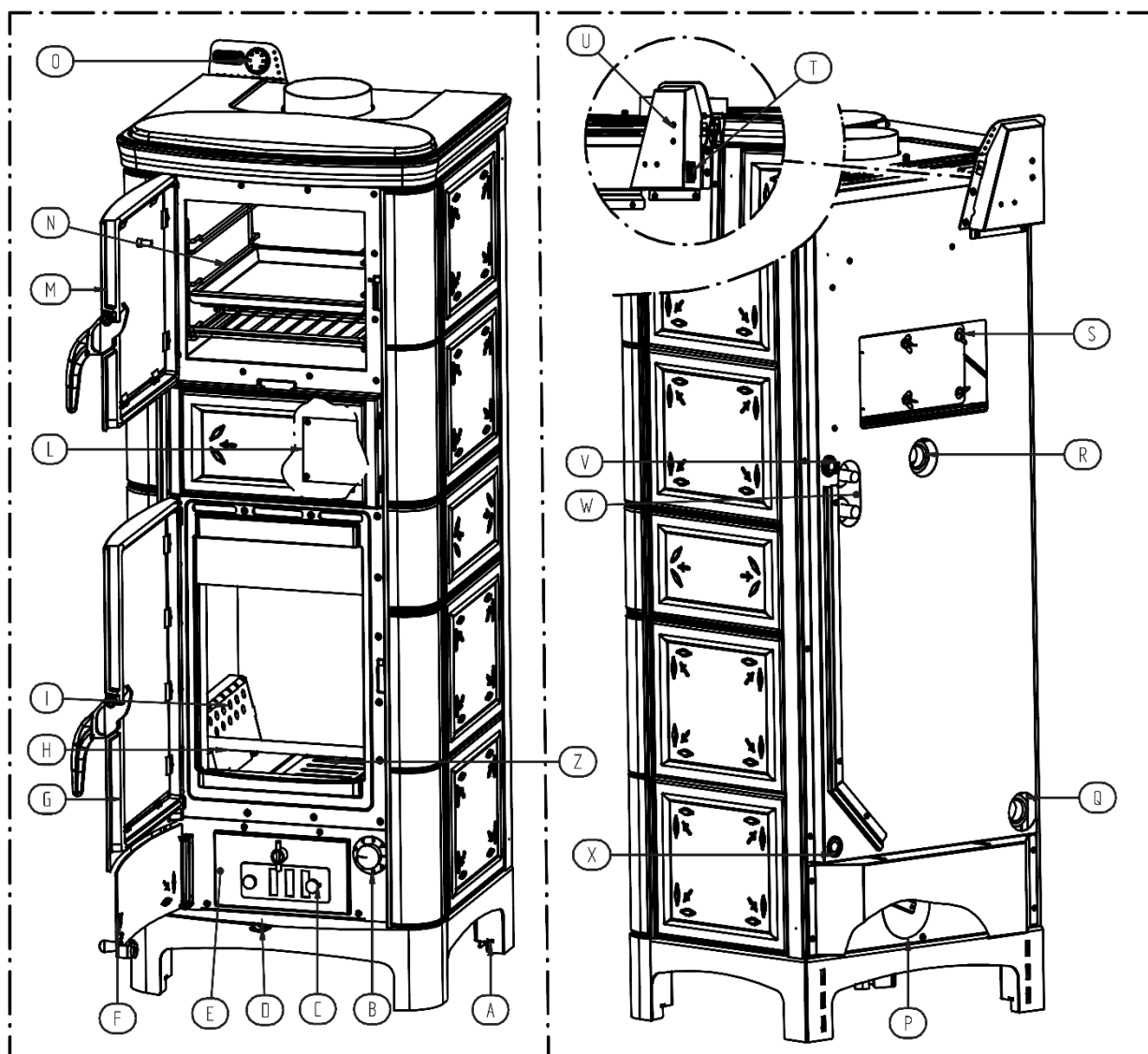
**MAXIMUM PERMITTED FUEL FEED: 4.6 kg**

**THE FUEL FEED INTERVALS MUST NOT BE LESS THAN 50 MINUTES. LOADING A LARGER QUANTITY OF FUEL OR LOADING SEVERAL TIMES IN AN HOUR EXPOSES THE COMPONENTS OF THE APPLIANCE TO VERY HIGH TEMPERATURES. FOR THIS REASON THE WARRANTY WILL NOT COVER ANY DAMAGE CAUSED BY PROLONGED EXPOSURE OF THE APPLIANCE TO THESE TEMPERATURES.**



The use of fuel that does not comply with the above specifications or the use of different substances or fuels will immediately void the appliance warranty. The appliance must not be used as an incinerator, and it is prohibited to use any liquid or gas fuel. Do not overload the stove with excessive quantities of fuel; adhere strictly to the maximum declared consumption.

**3.2 MAIN COMPONENTS**



**KEY**

A	Adjustable mounting feet	B	Primary air adjustment knob
C	Grill for rekindling the fire	D	Secondary air lever
E	Ash pan	F	Ash pan door
G	Feed door	H	Baffle plate
I	Secondary air box	L	Safety heat exchanger insertion plate
M	Oven door (only Ardhea-F EVO5)	N	Oven (only Ardhea-F EVO5)
O	Water thermometer	P	Automatic thermostat
Q	System return fitting 1 ¼" F	R	System delivery fitting 1 ¼" F
S	Cleaning cap	T	Pump active indicator light
U	Anticondensation thermostat	V	Sensor pocket
W	Fittings for safety exchanger ½" F	X	System drain/make-up ½" F
Z	Combustion chamber grate		

**B – Primary air adjustment knob**

It is used to regulate the primary air inflow. The primary air passes through the grate of the firebox and fuels the combustion to determine its power and speed. Rotate the knob towards zero to reduce the air inflow. On the contrary, turn the knob towards eight to increase the air inflow. To prevent or limit condensation, it is recommended to keep the control on levels 5-6.

**D – Secondary air lever**

It is used to regulate the flow of air passing through the holes in the secondary air boxes. While preheating, it facilitates the ignition of the second combustion. To decrease the air inflow, shift the lever in the direction of the "-" sign. Whereas to increase the air inflow, shift it in the direction of the "+" sign.

## 4 – INSTALLATION

### 4.1 APPLIANCE LOCATION



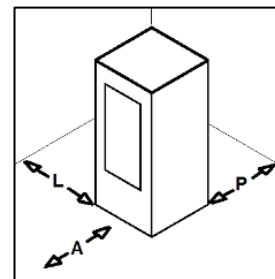
Follow the general guidelines set out in paragraph 1.1 to the letter. Be aware that the flooring of the installation site must be capable of withstanding the weight of the appliance and the water contained in it. If this requirement is not met, it is obligatory to adopt countermeasures (for example, load distribution plate ...).



**ATTENTION:** The room where the appliance is installed must be well ventilated and free from humidity and salty air. A high level of humidity or saltiness in the room can lead to the onset of rust or corrosion which will not be covered by warranty. The appliance must be positioned at a minimum safe distance from walls and furnishings. If inflammable materials are located in the vicinity of the appliance (e.g.: matchboarding, furniture, curtains, pictures and paintings, sofas) it is mandatory to comply with the minimum distances illustrated on the side.



If the flooring is made of wood or any other combustible material, it is mandatory to install a fireproof floor protector plate between the appliance and the floor. Installation in the vicinity of heat-sensitive materials is only permitted if suitable insulating and fireproof protection is placed between the object and the appliance (ref. Uni 10683). Failure to observe this instruction will immediately invalidate the warranty.



**A = 800 mm**  
**L = 300 mm**  
**P = 300 mm**

The installer must issue a certificate of conformity for the installation which includes the design plans and the following documents:

- a) Report containing the type of materials utilised.
- b) Project as defined in Article 5 of Ministerial Decree n° 37 22 January 2008.
- d) References to existing partial or previous declarations of conformity (e.g. flue outlet).
- e) Copy of the certificate of recognition of the professional technical qualifications.



These documents must, by law, be kept together with the installation, use and maintenance manual. The customer is responsible for verifying, directly or indirectly, that the installation has been carried out to perfection in accordance with relevant regulations in force. Do not install the appliance in unsuitable rooms such as bedrooms, bathrooms, garages and/or lock-ups. It is forbidden to place the appliance in environments with an explosive atmosphere.



**ATTENTION,** the appliance is not simply a household appliance: if the instructions set out in this manual are not followed and/or if installation of the appliance is not executed perfectly and/or the provisions in force are not strictly complied with, dangerous conditions could arise for both objects and persons. It is the user's responsibility to verify the presence, in the room, of a vent necessary for supplying oxygen to the appliance. It is strictly prohibited to install the appliance as inset or next to furniture.

### 4.2 UNPACKING THE APPLIANCE

The appliance is supplied packaged on a pallet; always use trolleys to move the appliance and the appliance must always be in a vertical position. Before positioning and installing it dismantle the appliance from the pallet as described:

- Remove the cover, the side panels and any fastening screws from the pallet.
- Remove the appliance from the pallet with the aid of a trolley. Given the weight of the appliance, we recommend that this operation be carried out by two people.
- Check that all the mobile parts are in place; remove the labels and stickers from the glass.

### 4.3 CONNECTION TO THE FLUE OUTLET



**Connection of the appliance to the flue outlet must be carried out in strict compliance with the instructions contained in this booklet and particularly with those in the dedicated chapter.**

## **5 – PLUMBING SYSTEM CONNECTIONS AND DIAGRAMS**

### **5.1 GUIDELINES FOR THE HYDRAULIC SYSTEM**



The hydraulic system must be installed by qualified personnel who are familiar with the standards mentioned above and who have the appropriate professional requirements to release the declaration of conformance in accordance with Ministerial Decree n° 37 of 22 January 2008. The system must be suitably sized in relation to the power of the generator.



**ATTENTION:** it is mandatory to earth the generator. If this instruction is not observed serious damage, which is not covered by warranty, will result to the body of the appliance. Have a skilled electrician check the earthing. There must be no electric potential (Volt) between the generator earth and the plant's real earth (earth plate). To prevent electrochemical corrosion of the appliance body do not use galvanised pipes and fittings. Other materials must be earthed with special earthing cables in order to obtain a unipotential earthing system.

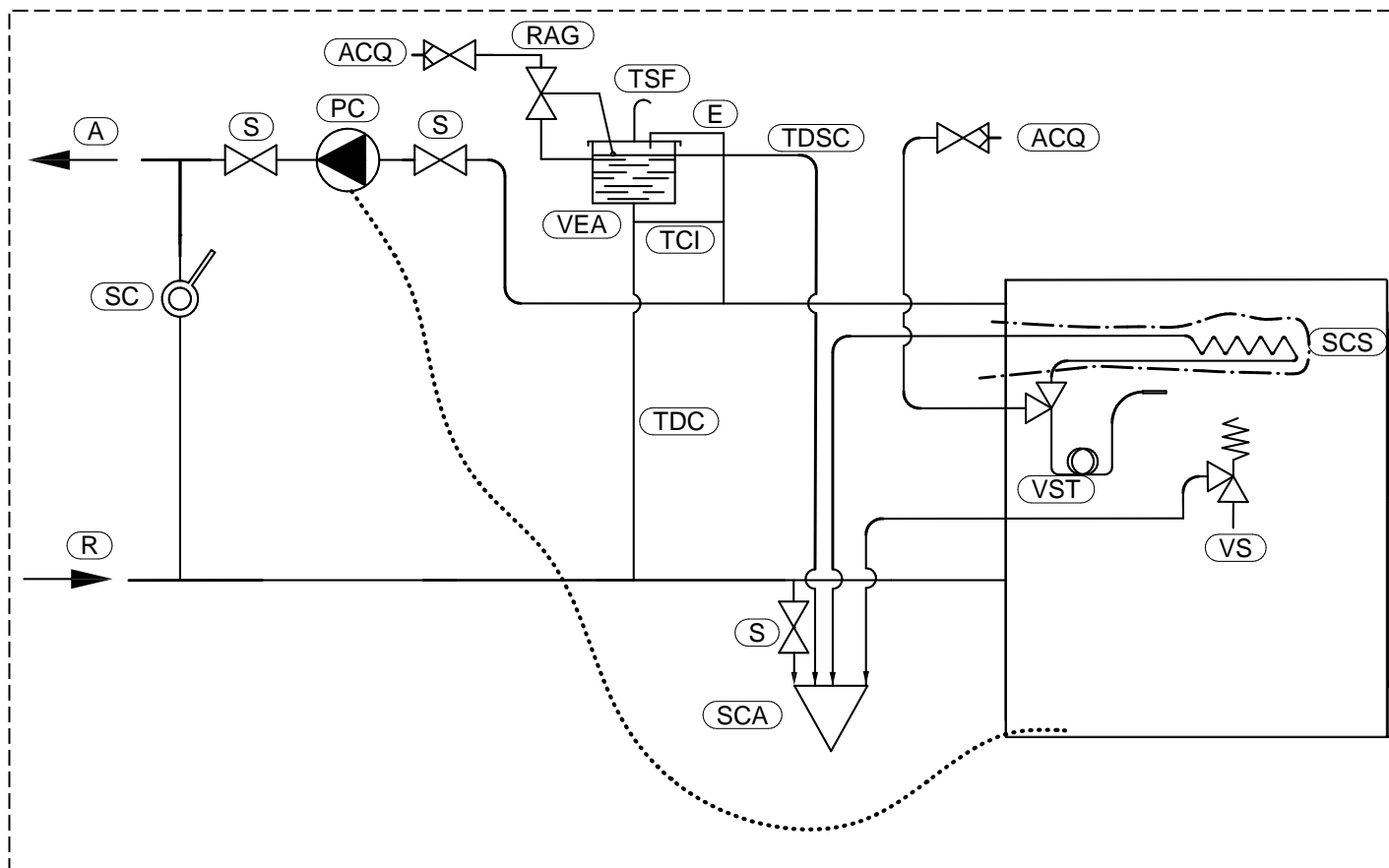
### **5.2 INSTRUCTIONS FOR EXECUTING THE CLOSED EXPANSION TANK HYDRAULIC SYSTEM**

To install the system with a closed expansion tank refer to the requirements laid down in EN 10412-2:2009 for appliances with nominal heat output not exceeding 35 kW. A closed expansion tank must be series-connected to the generator as protection for the system.

The nominal volume of the closed expansion tank must be sized in relation to the total volume of the water contained in the system. Thermorossi prescribes the size of the closed expansion tank as equal to 10% of the volume of water contained in the entire system. Any bulging of the boiler body caused by an incorrectly sized expansion tank will not be covered by the warranty.

The following chapter does not replace the above standards to which it makes reference. The qualified installer must in any case be fully aware of the above standards and their amending versions.

5.3 SCHEMATIC DIAGRAM OF TYPICAL OPEN EXPANSION TANK HYDRAULIC SYSTEM



A	Heating plant delivery	SCS	Safety heat exchanger (recommended)
ACQ	Water main inlet	TCI	Circulation tube
E	Safety tube from the boiler to the open expansion tank	TDC	Delivery pipe
PC	System circulating pump	TDSC	Overflow discharge pipe
R	Heating plant return	TSF	Vent pipe
RAG	Automatic make-up with float	VEA	Open expansion tank
S	On-off valve	VS	Safety valve 3 bar
SC	Gate valve (throttle according to pressure drop in the system)	VST	Thermal relief valve (recommended)
SCA	Discharge		

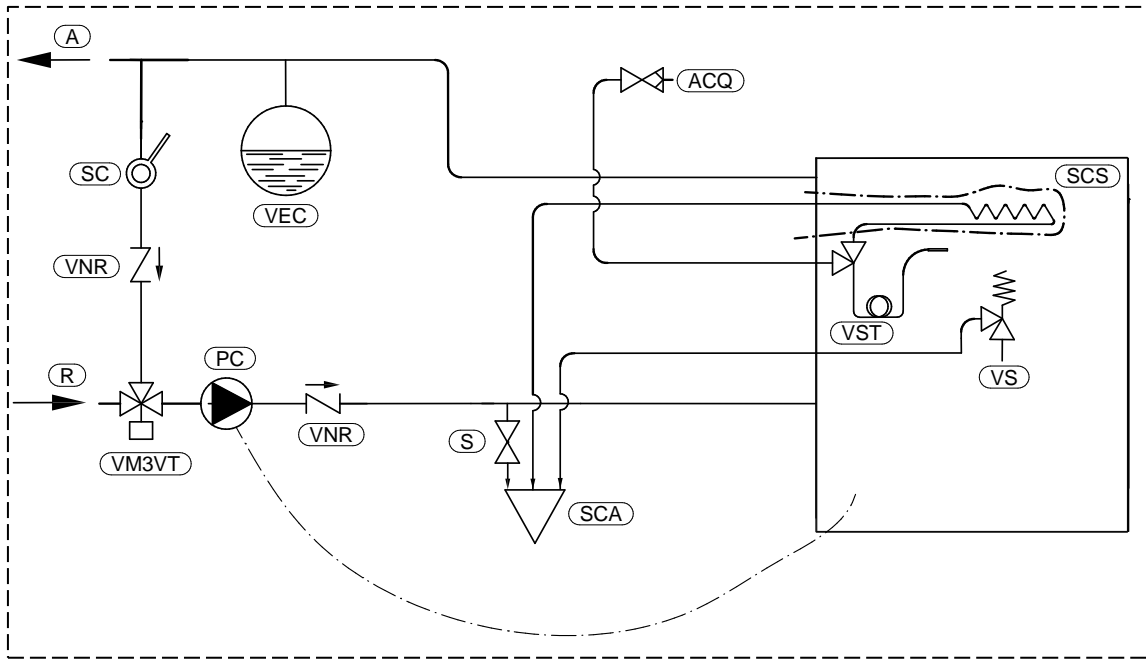


**ATTENTION:** it is mandatory to earth the generator. If this instruction is not observed serious damage, which is not covered by warranty, will result to the body of the appliance. Have a skilled electrician check the earthing. There must be no electric potential (Volt) between the generator earth and the system's real earth (earth plate). To prevent electrochemical corrosion of the appliance body do not use galvanised pipes and fittings. Other materials must be earthed with special earthing cables in order to obtain a unipotential earthing system.

**ATTENTION:** It is important to guarantee that the boiler return temperature always exceeds 55°C. For this reason we recommend installing a temperature control thermometer on the return. Act on the head of the mixing valve to adjust the temperature.

**ARDHEA EVO5 – ARDHEA-F EVO5**

**5.4 SCHEMATIC DIAGRAM OF TYPICAL CLOSED EXPANSION TANK HYDRAULIC SYSTEM**



A	Heating plant delivery	SCS	Safety heat exchanger
ACQ	Water main inlet	VEC	Additional closed expansion tank, sized to at least 10% of the volume of water contained in the system
PC	System circulating pump	VM3VT	Anti-condensation mixing valve
R	Heating plant return	VNR	Nonreturn valve
S	On-off valve	VS	Safety valve 3 bar
SC	Gate valve (throttle according to pressure drop in the system)	VST	Thermal relief valve
SCA	Discharge		



**ATTENTION:** it is mandatory to earth the generator. If this instruction is not observed serious damage, which is not covered by warranty, will result to the body of the appliance. Have a skilled electrician check the earthing. There must be no electric potential (Volt) between the generator earth and the system's real earth (earth plate). To prevent electrochemical corrosion of the appliance body do not use galvanised pipes and fittings. Other materials must be earthed with special earthing cables in order to obtain a unipotential earthing system.

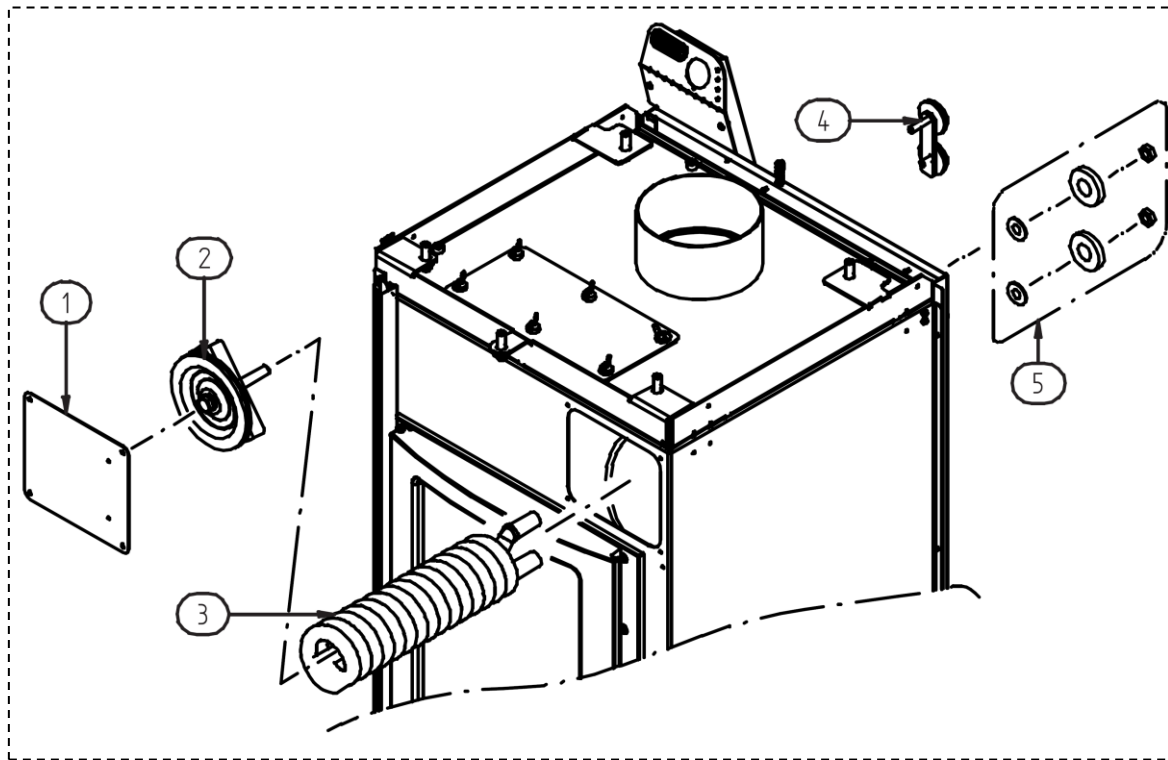
**ATTENTION:** It is important to guarantee that the boiler return temperature always exceeds 55°C. For this reason we recommend installing a temperature control thermometer on the return. Act on the head of the mixing valve to adjust the temperature.





## 6 – ASSEMBLING THE COMPONENTS

### 6.1 INSTALLATION OF THE SAFETY HEAT EXCHANGER (OPTIONAL)

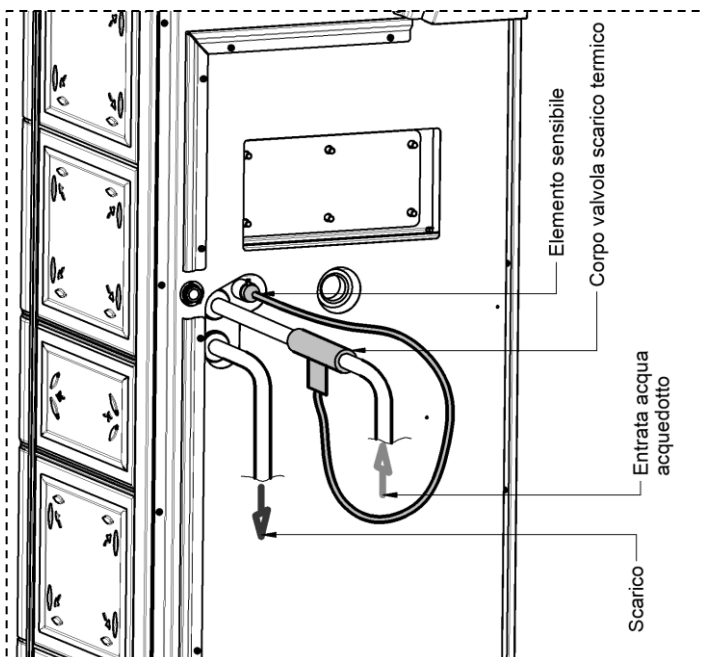


Install the safety heat exchanger in accordance with the following procedure:

- 1) Remove the safety heat exchanger insertion plate (1).
- 2) Slightly loosen the nut in the flange (2) and remove the flange.
- 3) Remove the two rear plugs (4).
- 4) Insert the safety heat exchanger (3) from the front side and slide out from the rear holes both fittings of the heat exchanger, and fix it to the boiler using the fixing elements (5) in the following order: gasket O-ring, conical washer with the concave side towards the gasket and nut.
- 5) Remount the flange (2) and the plate (1).
- 6) **ATTENTION:** before reassembling the remaining parts make sure that the gaskets are tight by bringing the system to pressure.

LEGENDA	KEY
Elemento sensibile	Sensitive element
Corpo valvola scarico termico	Thermal relief valve body
Entrata acqua acquedotto	Water main inlet
Scarico	Outlet

### 6.2 MOUNTING THE THERMAL RELIEF VALVE



When installing a thermal relief valve, install a certified and calibrated two-way thermal relief valve at the exchanger inlet, following the instructions provided by the manufacturer and install a discharge pipe. The thermal relief valve must have the following characteristics:

- Double safety sensor for solid fuel generators (max. operating pressure): 10 bar
- Temperature range: 5÷110°C - calibration temperature 98°C
- Discharge capacity with  $\Delta p = 1$  bar and  $T=110^\circ\text{C}$ : 3,000 l/h - capillary tube length: 130 mm
- **Certified to standard EN 14597**

Install the valve sensitive element in the special pocket located at the back, as indicated in the figure.

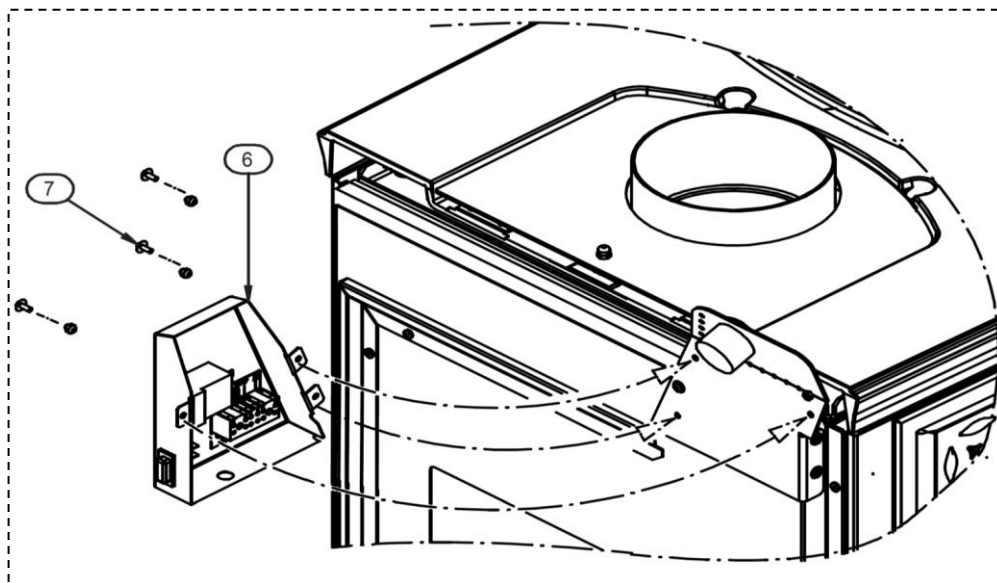
**ATTENTION: A CONNECTION MUST BE MADE BETWEEN THE SAFETY VALVE AND THE OUTLET TO PREVENT DAMAGING MATERIALS SURROUNDING THE APPLIANCE WHEN THE VALVE IS ACTIVATED. ATTENTION: IF THE SAFETY HEAT EXCHANGER IS INSTALLED TO PRODUCE DOMESTIC HOT WATER, THE GUARANTEE FOR THE GENERATOR IS IMMEDIATELY VOIDED.**

**6.3 INSTALLATION OF THE CIRCULATING PUMP**

It is mandatory to connect the circulating pump (not supplied as standard) to the dedicated terminal block.

**Failure to connect the circulating pump to the terminal block will immediately void the manufacturer's warranty.**

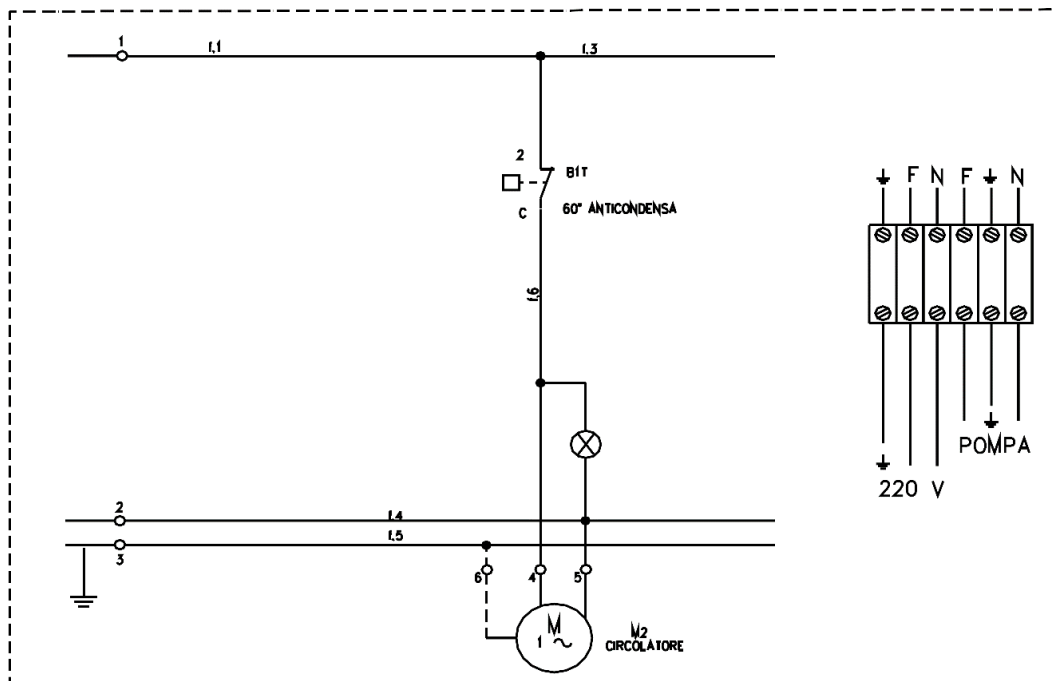
The terminal block is located in the electric panel. To reach the terminal block, remove the 3 screws (7) of the electric panel (6), as shown in the next figure.



Connect the power supply (220 V) to the terminals as indicated in the figure below. Then connect the circulating pump to the terminals (PUMP). The circulating pump will thus activate as soon as the water in the boiler will exceed the temperature of about 60°C.



This operation must be exclusively performed by qualified professional staff, as set forth by Decree no. 37 of 22nd January 2008 and applicable laws on the subject. Before performing said task, make sure the power supply cable is disconnected from the electrical power socket.



**ATTENTION:** it is mandatory to earth the generator. If this instruction is not observed serious damage, which is not covered by warranty, will result to the body of the generator. Have an electrician check the earthing. There must be no electric potential (Volt) between the earth of the generator and the actual earth of the system. To prevent electrochemical corrosion of the boiler body do not use galvanised pipes and fittings. Dedicated ground wires must be used to ground all other materials.

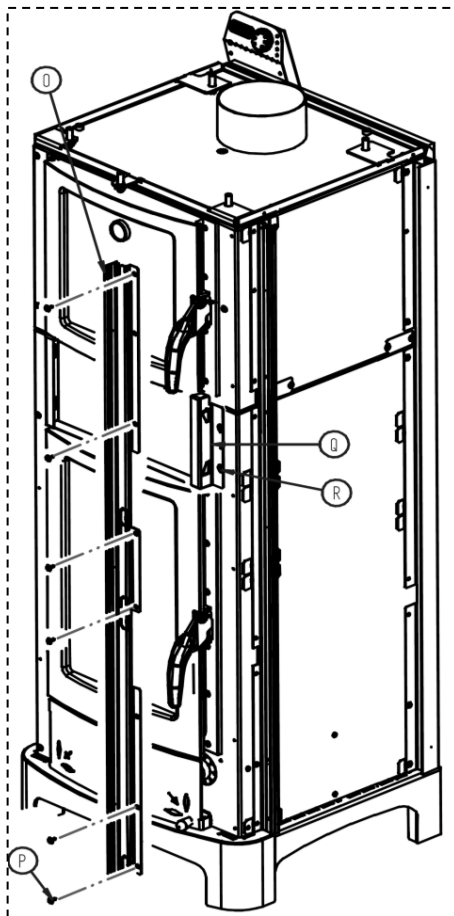
LEGENDA	KEY
60° ANTICONDENSA	60° ANTICONDENSATION
POMPA	PUMP
CIRCOLATORE	CIRCULATING PUMP

**ARDHEA EVO5 – ARDHEA-F EVO5**

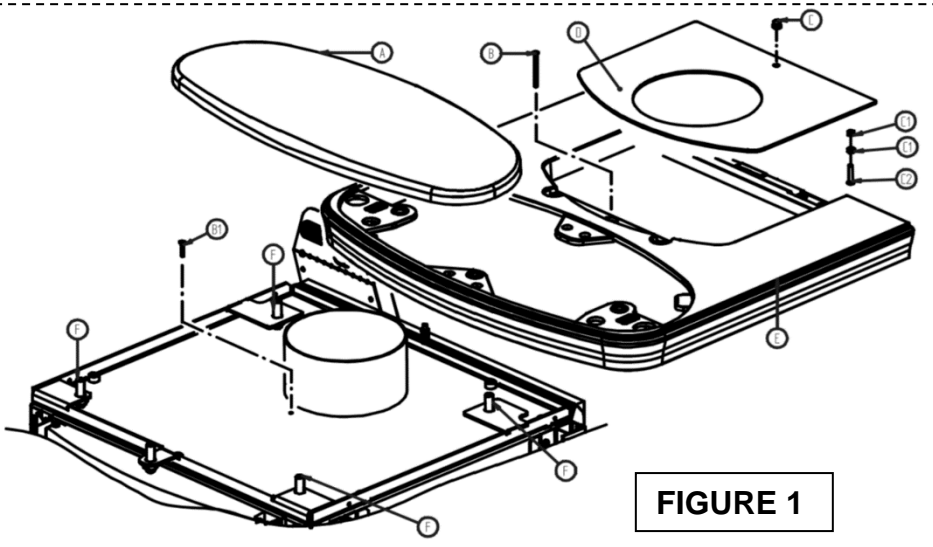
**6.4 MOUNTING THE CERAMIC CASING**

To install the ceramics, proceed as follows:

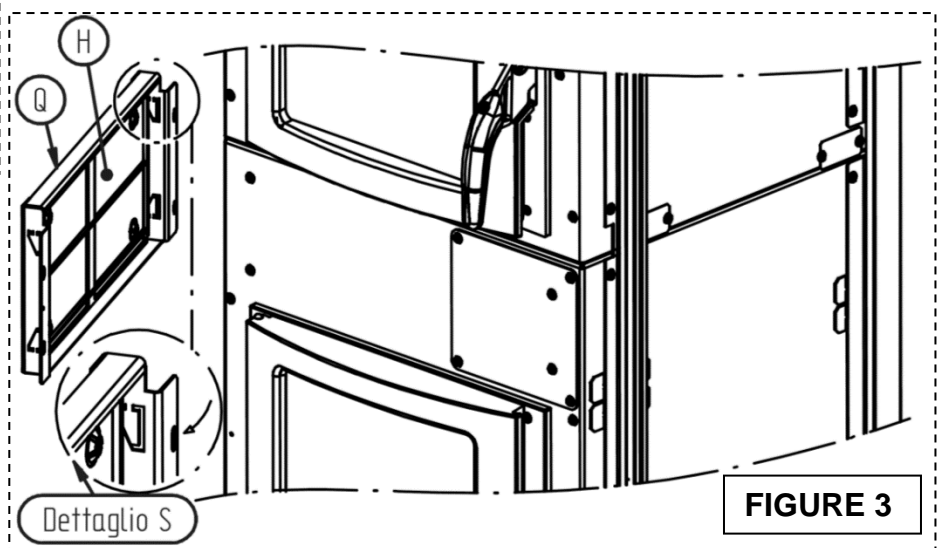
- 1) Extract the ceramics from their packaging taking extra care as they are particularly fragile.
- 2) Remove the cover **D** by unscrewing the screws **C-C1-C2** (figure 1).
- 3) Undo screw **B** and remove the cast iron cover **E** (figure 1), screw in screw **B1** (supplied) in the hole freed by screw **B**.
- 4) Undo screws **P** and remove the ceramic supports **O** (figure 2).
- 5) Undo the 4 screws **R** and remove the support **Q** (figure 2).
- 6) Fasten the ceramic **H** to support **Q** by bending the 4 wings as indicated in Detail **S** and fasten it once again with the screws (R) removed earlier (figure 3).
- 7) Next, fasten the previously removed ceramic supports **O** with screws **P**.
- 8) Then fasten ceramics **G , H , I , L**. To firmly fasten the ceramics to the product, bend the "wings" (4 for each ceramic), before inserting the ceramic as shown in Detail **N** and Detail **M** (for heater mod. ARDHEA-F EVO5 follow the indications in Figure 4, for heater mod. ARDHEA EVO5 follow the indications in Figure 5).
- 9) Next, place the cast iron cover **E** and raise or lower it by means of the screws **F** (figure 1).
- 10) Mount cover **D** once again using screws **C, C1, C2** and install ceramic **A**.



**FIGURE 2**

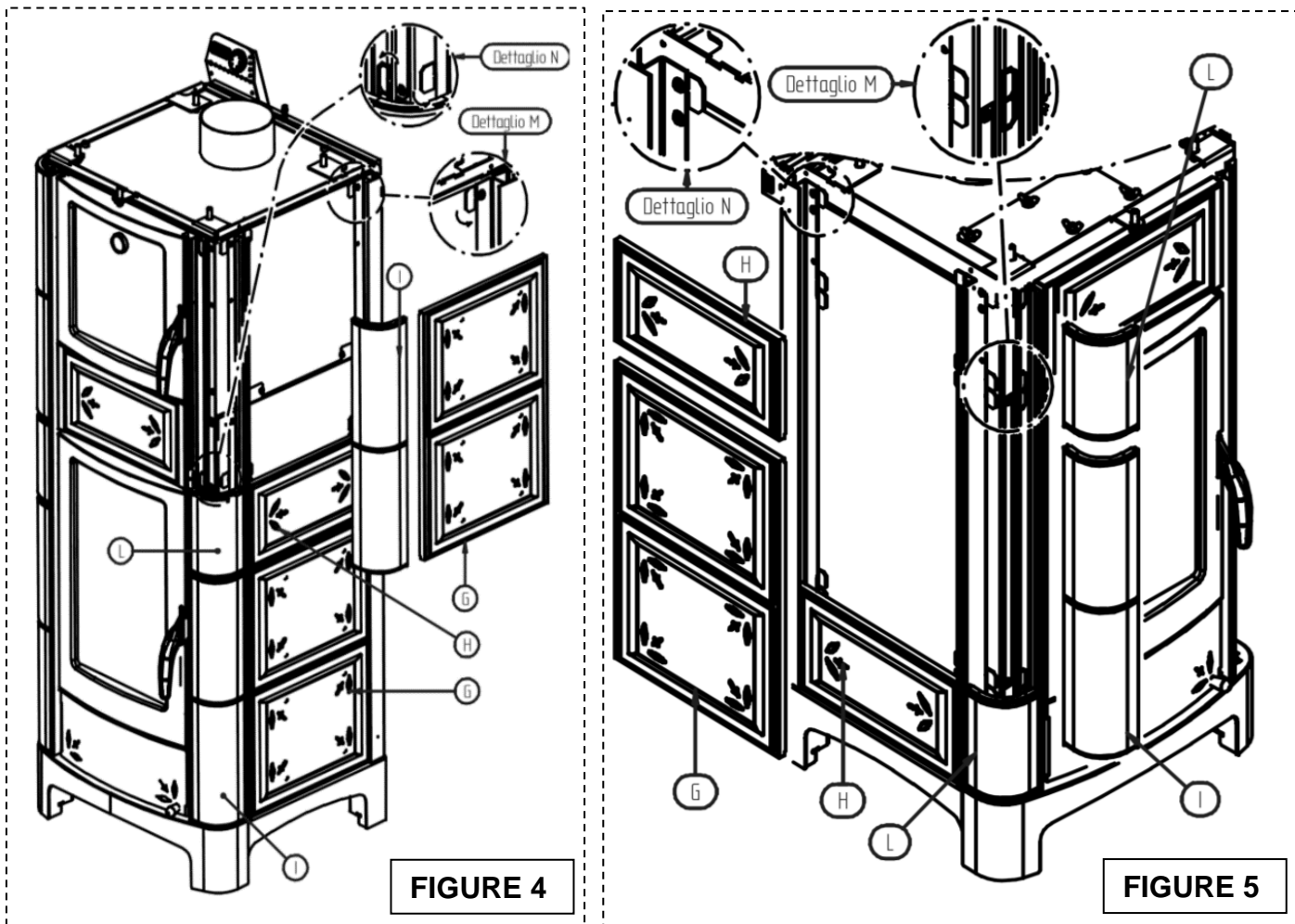


**FIGURE 1**



**FIGURE 3**

LEGENDA	KEY
FIGURA	FIGURE
Dettaglio S, N, M	Detail S, N, M



**FIGURE 4**

**FIGURE 5**



ATTENTION: The majolica elements are handcrafted so they could contain subtle surface imperfections, crazing or shade variations. The layer of glaze has an expansion factor that is different to that of the majolica tiles which is what causes the hairline cracks. This phenomenon is a natural process and is not a defect. We recommend cleaning the majolica tiles with a dry microfibre cloth and only when the appliance has cooled down. Using moist or wet cleaning cloths would show up the natural crazing even more.

## 7 – USE OF THE APPLIANCE



The appliance, when operating, is hot to the touch, particularly the door of the combustion chamber: consequently, take care not to touch any surface. Your appliance has obtained the CE marking. The product must not be used by children, by persons with physical or mental impairments, by persons who are not familiar with the instructions for use and maintenance of the product (the instructions are found in this installation, use and maintenance manual). During the heating and cooling stages the appliance is exposed to considerable thermal expansions that can cause light expansion sounds. This is a normal process and is not a defect of the product.



ATTENTION: the door must always remain shut tight when the appliance is operating. While the appliance is in operation, the smoke exhaust pipes can reach extremely high temperatures: do not touch them! It is strictly forbidden to use any type of liquid or gaseous fuel to light the appliance. Do not place non-heat resistant or inflammable or combustible objects in the vicinity of the appliance: keep them at a suitable distance. Do not place wet clothing to dry on the appliance. When using a clothes horse, keep at a suitable distance. During the first lighting it is quite normal for the paint on the product to give off a slight smell as it completes its drying process. It is recommended to ventilate the room until the paint has completely dried.

### 7.1 LIGHTING

To startup the stove proceed as follows:

- 1) Open the primary air adjustment knob (B) completely, setting it to value (8).
- 2) Open the grill for rekindling the fire completely (C).
- 3) Open the secondary air lever completely (D).



**ATTENTION: BEFORE LIGHTING THE APPLIANCE MAKE SURE THAT THE GRATE IN THE FIREBOX IS CLEAN, THAT IS THAT THERE IS NO ASH OR COMBUSTION RESIDUES.**

- 4) Open the firebox door, place some kindling in the firebox and light it with paper or any other tinder available on the market, then close the firebox door.



**IT IS PROHIBITED TO USE ANY LIQUIDS OR GASES SUCH AS ALCOHOL, PETROL, ETC. TO LIGHT OR REKINDLE THE FIRE.**

- 5) Do not leave the appliance unsupervised while the lighting process is still in progress (roughly 30 minutes to complete the process) or whenever there are abundant burning embers present.



- 6) Once the lighting phase is completed, close the grill for rekindling the fire (C).



**ATTENTION: THE DOOR OF THE COMBUSTION CHAMBER MUST ONLY BE OPENED FOR THE LIGHTING OPERATIONS, FOR STOKING AND FOR REMOVING RESIDUAL MATERIAL. DURING NORMAL OPERATION THE FIREBOX DOOR MUST REMAIN SECURELY CLOSED.**

**ARDHEA EVO5 – ARDHEA-F EVO5**

Leaving open the grill for rekindling the fire (C) during normal operation results in higher fuel consumption than the declared quantity, a considerable drop in efficiency and exposure of the appliance to extremely high temperatures. For this reason the warranty does not cover any direct or indirect damages caused by prolonged exposure of the appliance to these temperatures.

**7.2 REFUELLING**

The stove is an intermittent combustion appliance so it requires refuelling. Once combustion is achieved inside the combustion chamber and consequently there are embers present, proceed with the first fuel feed:

- 1) Open the grill for rekindling the fire if necessary (C).
- 2) Open the firebox door slowly to minimise the risk of smoke escaping and use the riddling tool to spread the embers.

**N.B. It is prohibited to light or reload the fuel with a bed of embers higher than 3 cm as this does not guarantee correct use of the appliance.**

- 3) Take two or three logs, each of which must not exceed the weight specified in the technical data table, and lay them parallel in the centre of the grate in the combustion chamber, as illustrated in the figure below. Slowly close the firebox door.
- 4) Set the primary air control between 5 and 8, as much as required.
- 5) Close the grill for rekindling the fire if necessary (C).

To rekindle the fire clear the ash from the air passage slots to promote better combustion. Do not add additional fuel until the previous load has burnt or is reduced to embers, then open the firebox door slowly and place the logs in an orderly manner on the bed of embers. Complete the operation by slowly closing the door and return the air control and levers to the positions described above.

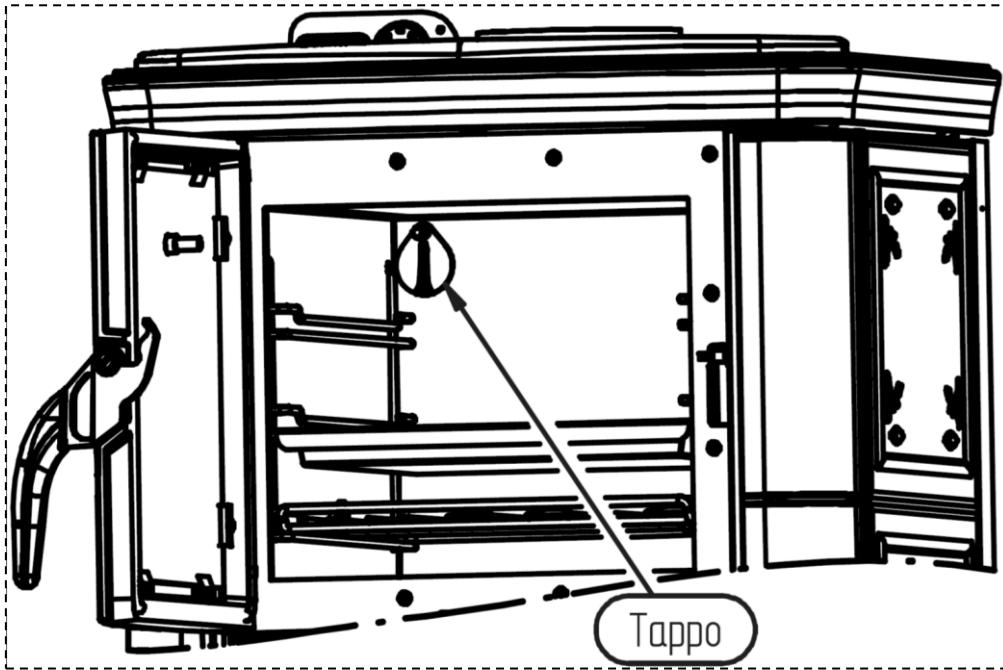
**7.3 OVEN (ONLY ARDHEA-F EVO5)**

Model Ardhea-F Evo5 is supplied as standard with a thermometer installed on the glass of the oven door.



**THE THERMOMETER GIVES AN APPROXIMATE, NOT PERFECTLY RELIABLE, READING OF THE OVEN TEMPERATURE. THE OVEN TEMPERATURE IS STRICTLY RELATED TO THE QUALITY OF THE FUEL, THE FLUE OUTLET DRAUGHT, THE TEMPERATURE OF THE DELIVERY WATER AND OTHER FACTORS, AND MAY EXPERIENCE SUDDEN VARIATIONS. THEREFORE ALWAYS VISUALLY CHECK THE FOOD FOR DONENESS.**

In the oven there is also a cooking vapours outlet plug. We recommend leaving it slightly open at all times while cooking.



#### 7.4 PRESCRIPTIONS FOR CORRECT OPERATION

LEGENDA	KEY
Tappo	Plug

- Respect the maximum declared consumption, do not overload the stove with excessive quantities of fuel as this could cause damage.



**LOADING A LARGER QUANTITY OF FUEL OR LOADING SEVERAL TIMES IN AN HOUR WOULD EXPOSE THE COMPONENTS OF THE APPLIANCE TO VERY HIGH TEMPERATURES. FOR THIS REASON THE WARRANTY WILL NOT COVER ANY DAMAGE CAUSED BY PROLONGED EXPOSURE OF THE APPLIANCE TO THESE TEMPERATURES.**



**DO NOT THROW THE WOOD INTO THE COMBUSTION CHAMBER, PLACE IT IN GENTLY. THROWING THE WOOD COULD END UP BREAKING PARTS. DAMAGE CAUSED IN THIS WAY IS NOT COVERED BY WARRANTY.**

- The appliance must not be used as an incinerator, the use of liquid or gaseous fuels is prohibited.
- Adhere strictly to the operating instructions set out in this manual.
- Always verify that the fuel loaded into the combustion chamber lights correctly. Make sure that this always occurs to avoid any buildup of combustible gases. The buildup of a high quantity of combustible gases could exceed the mechanical resistance of the glass and other components of the stove. For this reasons the manufacturer disclaims all responsibility.
- In adverse weather conditions, such as for example low pressure, windy or rainy days or days with high outside temperatures, the effect could be a drop in draught or reverse draught. In these situations the flue gases may not be completely exhausted. Consequently, in these cases it is necessary to increase the primary air and load the smallest amount of fuel in order to reactivate the draught of the flue outlet. If you notice the smell of smoke in the room or stagnation of gases inside the combustion chamber avoid using the appliance.

## 8 - CLEANING AND MAINTENANCE

### 8.1 FOREWORD



To guarantee correct operation and optimal performance of the appliance at all times carry out the operations described below. Observe the recommended frequency.

If the product is unused for a prolonged period of time before starting up, it is mandatory to inspect the smoke channel and outlet to ensure that there are no obstructions. It is important to carefully follow the instructions set out below: failure to observe these instructions could cause serious damage to the product, to the system, to objects and to persons using the appliance.



Attention: do not wet or touch the appliance with wet hands. Never vacuum hot ash: this could damage the vacuum device. All the cleaning operations described in this manual must be carried out when the appliance is cold.

**The user must periodically clean the appliance, or have an authorised service centre clean it, as described in this manual. Moreover, once a year it is advisable to have an inspection carried out of the functionality of the flue outlet.**

### 8.2 CLEANING AND MAINTENANCE

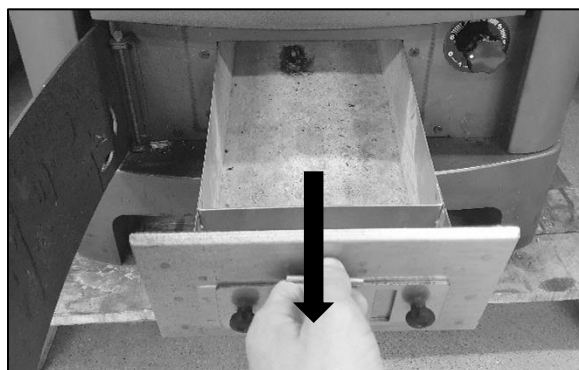
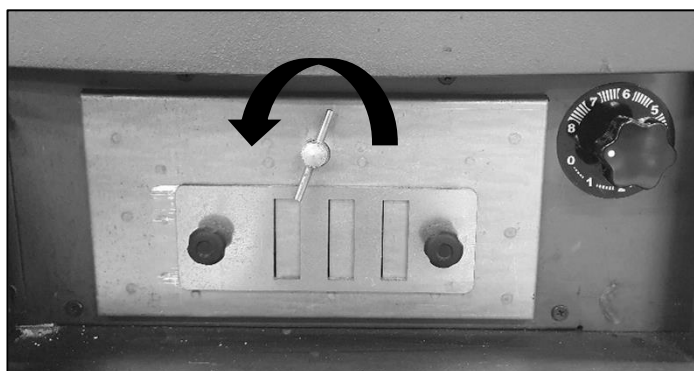
#### EVERY TIME YOU REFUEL:

- If necessary thoroughly clean the grate of the combustion chamber by de-ashing the grate through the slots. The air passage through the firebox grate must always be kept free from obstructions. Use the supplied riddling tool for this operation.



#### EVERY TWO DAYS or WHENEVER NECESSARY:

- Empty the ash pan. To remove the ash pan, simply turn the pin counterclockwise, as shown in the figure. We recommend emptying the ash pan regularly before it fills up completely. Once emptied, we recommend closing the pin tightly by turning it clockwise until the end stop.



#### EVERY 15 DAYS or WHENEVER NECESSARY:

- Clean the inner surfaces of the flue gas path and the tube bundle. To do so, open the feed door, remove the vermiculite tile (figure 1) and open the S plug, which in model ARDHEA-F EVO5 is located at the back (figure 2), whereas in model ARDHEA EVO5 it is located under the cast iron cover (figure 3).



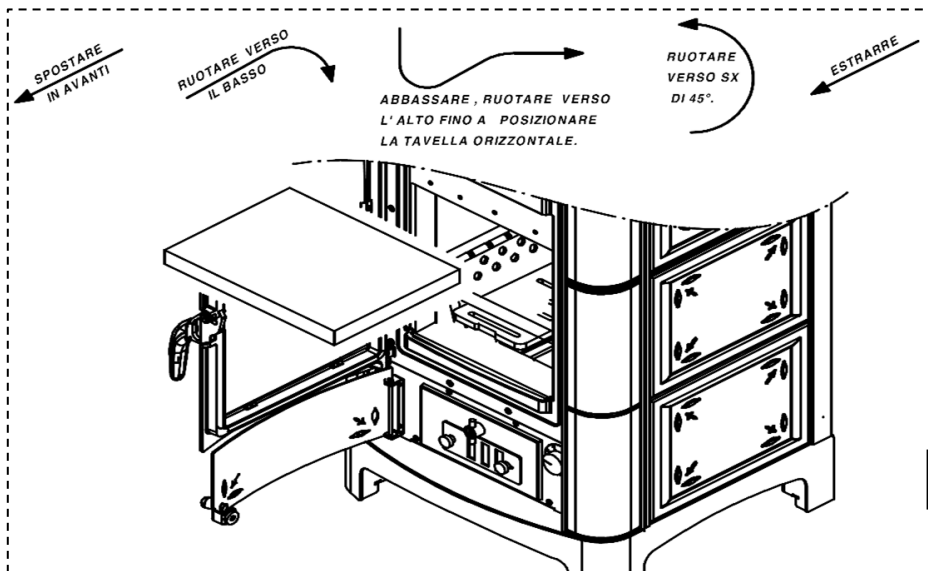


FIGURE 1

LEGENDA	KEY
SPOSTARE IN AVANTI	MOVE FORWARD
RUOTARE VERSO IL BASSO	ROTATE DOWNWARDS
ABBASSARE, RUOTARE VERSO L'ALTO FINO A POSIZIONARE LA TAVELLA ORIZZONTALE	LOWER, ROTATE UPWARDS UNTIL THE TILE IS HORIZONTAL
RUOTARE VERSO SX DI 45°	ROTATE TO THE LEFT BY 45°
ESTRARRE	EXTRACT
FIGURA	FIGURE

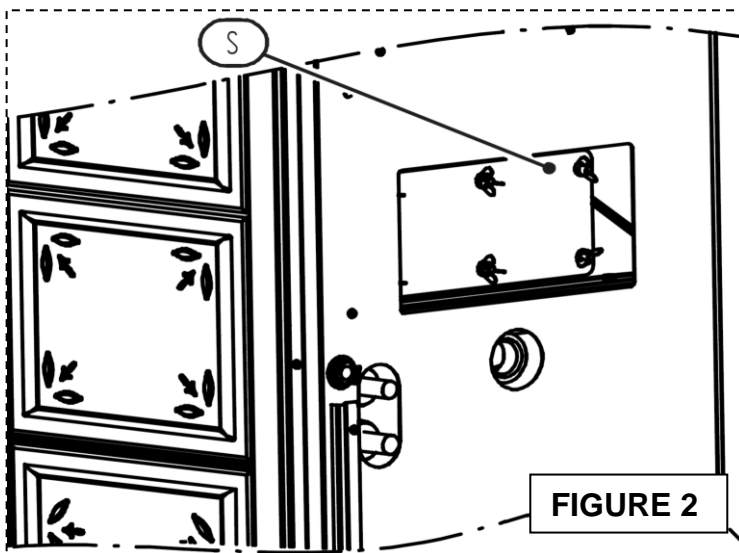


FIGURE 2

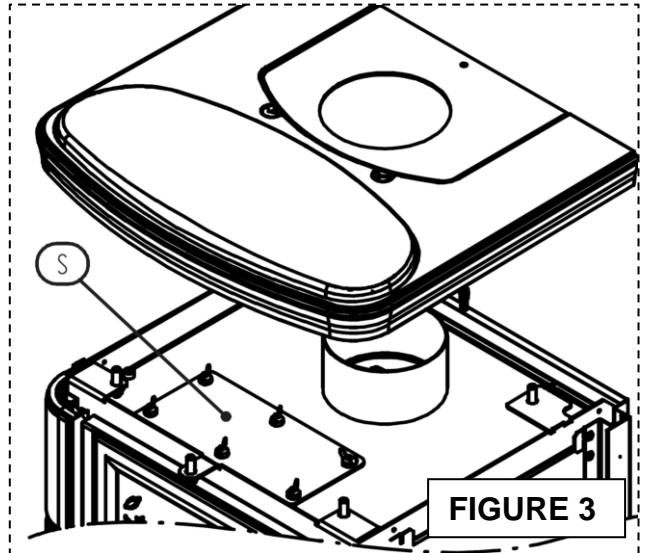


FIGURE 3

**AT LEAST ONCE A YEAR:**

- Clean the flue outlet. If there are any horizontal sections, inspect them and clean out any ash and soot deposits before they block the passage of the flue gases.

**CLEANING THE GLASS:**

- The glass must only be cleaned when the appliance is cool, using little water and mild detergents.

**AT THE END OF THE WINTER SEASON OR WHENEVER NECESSARY:**

- Perform a thorough overall cleaning of the firebox and pans with brushes and vacuum cleaners.



A vacuum device simplifies the ash cleaning procedure. The front and side casings must be cleaned when the heater is cold using a soft cloth and water. The door of the combustion chamber must only be opened when the appliance has completely cooled down: when it is opened it is normal for some ash to spill onto the floor.



**ATTENTION:** after cleaning it is mandatory to check that the combustion chamber door is firmly closed and airtight. **ATTENTION:** the generator, the smoke channel and the flue outlet must be cleaned in accordance with the specifications described above and use of inflammable products is strictly forbidden: using inflammable products can create dangerous situations. Failure to carry out the necessary maintenance or if only partial maintenance is carried out will affect the correct functioning of the appliance. Any problems resulting from total or partial lack of cleaning or maintenance will immediately void the warranty.



**ATTENTION:** if the appliance remains inactive (and/or not used) for over a month, the generator, the smoke discharge tube and the flue outlet must be thoroughly cleaned and checked for any possible obstructions (e.g. birds nests in the chimney cap) before restarting.

## 9 - SMOKE DISCHARGE TUBE

### 9.1 FOREWORD



Due to the frequent accidents caused by poor functioning of flue outlets installed in private dwellings, we have prepared the following paragraph to assist the installer in his inspection of the parts concerned with eliminating the gases produced by combustion.



The exhaust pipe must be installed in compliance with regulations UNI7129, UNI 10683, and with the stated reference values. In particular, the outlet must comply with fire prevention regulations.

**It is important to carefully follow the instructions set out below: failure to observe these instructions could cause serious damage to the product, to the system, to objects and to persons using the appliance.**

### 9.2 ROOM VENTILATION



ATTENTION: The presence of extraction fans or similar appliances, if operating in the same room or space in which the product is installed, could cause problems for the correct operation of the product.

ATTENTION: do not obstruct the vents or the air inlets on the appliance.

The room where the appliance is installed must have a good air inflow to guarantee air for the appliance for the combustion process and for ventilation of the room. The natural air inflow must take place directly through permanent openings on the outer walls or through single or multiple ventilation ducting.

The ventilation air intake must be located away from pollution sources.

The openings in the walls must comply with the following conditions:

- have an unobstructed section of at least 6 cm<sup>2</sup> for each kW of installed thermal power, with a minimum limit of 100 cm<sup>2</sup>;
- be made in such a way that the vent openings, both on the inside and outside of the wall, cannot be obstructed;
- be protected with grills or similar systems that do not reduce the opening section indicated above;
- be situated at a height near-floor level and they must not obstruct the correct operation of the combustion product discharge devices; if this position is not possible, the section of the ventilation openings must be enlarged by at least 50%.



The following chapter is not intended to replace UNI 7129, UNI 10683 and EN13240 standards. The qualified installer must in any case be fully aware of this standard and its amending versions.

### 9.3 SMOKE OUTLET



The smoke channel, the exhaust pipe, chimney and flue outlet (defined as the system for the evacuation of combustion products), are parts of the heating system and they must comply with the legislative requirements of the Ministerial Decree D.M. 37/08 (ex Italian Law 46/90) and to the applicable specific installation regulations, according to the type of fuel. Fireplaces, stoves and barbecues must not be installed in locations where gas appliances type A and type B are present and operating (for the classification see UNI 10642 and UNI 7129). The connection between the appliance and the flue outlet must only receive exhaust from one heat generator.



The installer must provide one or more access points on the flue outlet to check the emissions once the appliance has been installed; these access points must be made in such a way as to be airtight sealable to prevent exhaust gas leaks.



It is recommended to provide insulation and to ensure the optimal sizing of the flue outlet in order to avoid the possible risk of condensation forming in the flue outlet.

#### 9.3.1 CHIMNEY TYPES

The following types of chimneys, constructed as described, are possible:

- System: chimney installed using a combination of compatible components (flue liner, insulation, outer casing, etc.), manufactured or specified by a single manufacturer and EC certified in accordance with the applicable standard;
- Composite chimney: chimney installed and built on site using a combination of compatible components such as flue liner (wall in direct contact with the flue gases), possibly also insulation and outer casing (wall) that may be supplied by different manufacturers or by the same manufacturer.
- Relining: operation involving the installation of a specific pipe in an existing shaft (even if newly constructed) made of non-combustible materials, free from obstructions and for single use.

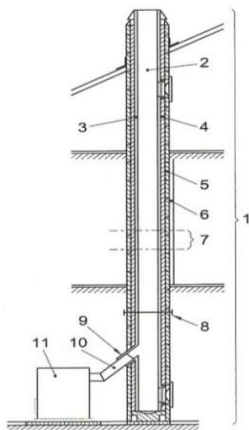
**9.3.2 FLUE OUTLET / FLUE SYSTEM COMPONENTS**

Components and accessories of a

chimney

Key

- 1 Chimney
- 2 Flow path
- 3 Smoke discharge tube
- 4 Thermal insulation
- 5 External wall
- 6 Outer lining
- 7 Flue outlet section
- 8 Multiwall chimney
- 9 Connector
- 10 Flue pipe
- 11 Heat generator



Every chimney must have minimum number of components as laid down by standard UNI EN 10683 which are also indicated in the figure on the left.



Wall outlets, that is outlets installed on the outer front wall without the use of a chimney/flue outlet /flue pipe to convey the combustion products to the roof, are strictly prohibited.

**9.3.3 CONTROLS PRIOR TO INSTALLING THE APPLIANCE**

The user must possess a certificate of conformance for the flue outlet (Ministerial Decree 22 January 2008, no. 37).

The flue outlet must be built in compliance with UNI 10683.

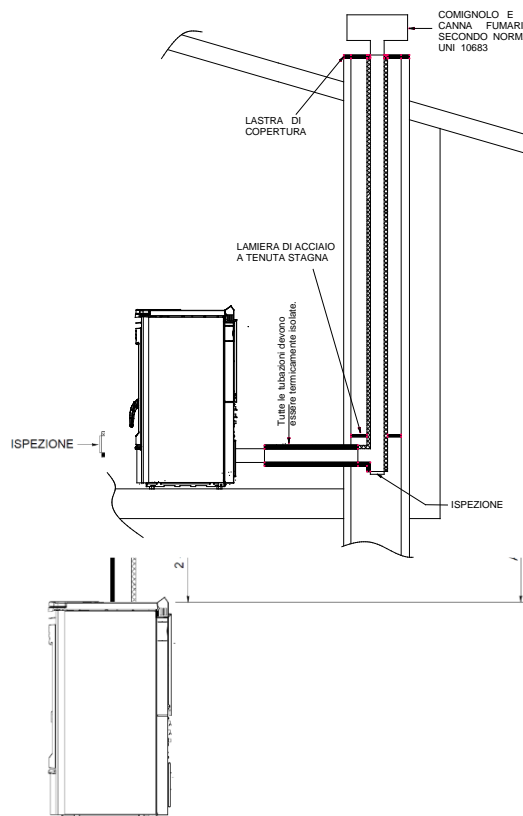
The smoke exhaust illustrated in the figure on the side is the best solution required to ensure that the flue gases are discharged. If you prefer to exhaust the smoke from the roof insert a union tee with inspection cap, connecting brackets suitable for the height of the flue outlet, flashing that crosses the roof and chimney cap to protect against bad weather conditions.

If you decide to use the classic masonry exhaust provide a union tee with inspection cap and suitable supporting brackets. If the flue outlet is too big, it is necessary to insert a stainless steel or porcelain-coated steel tube with suitable diameter.

Seal area where the inlet and outlet part of the smoke exhaust meets the wall. It is strictly forbidden to apply mesh to the end of the outlet tube, as it could cause the appliance to malfunction.

If the smoke tube is installed in a fixed position, it is advisable to provide inspection openings for clean-out purposes especially in the horizontal sections.

See the diagram. These openings are essential to allow for the removal of ash and unburned products which tend to accumulate along the discharge path. Seal the fittings with red silicone (resistant to 350°C).



The outer casing of the tube must be made with insulating material (mineral wool, ceramic fibre) or use pre-insulated tubing.

LEGENDA	KEY
COMIGNOLO E CANNA FUMARIA SECONDO NORMA UNI 10683	CHIMNEY CAP AND FLUE OUTLET ACCORDING TO UNI 10683 STANDARD
Tutte le tubazioni devono essere termicamente isolate	All the pipes must be thermally insulated
ISPEZIONE	INSPECTION
2-3 metri MAX	2-3 metres MAX.
Pendenza non inferiore al 5%	Minimum slope 5%
ALTEZZA SUPERIORE A 4 m	HEIGHT MORE THAN 4 m.
2 metri MAX	2 METRES max

**THE FLUE OUTLET MUST BE USED ONLY FOR THE APPLIANCE.**

It must be possible to inspect and remove all the smoke tube sections for clean-out purposes.



ATTENTION: if the flue outlet is not sufficiently insulated and /or if it is too long it could generate condensation. It is advisable to provide a condensation drain near the smoke outlet of the appliance. The appliance must always and only be installed in a single flue outlet system dedicated exclusively to the appliance.

If the generator is connected to a non-compliant flue system the appliance could rapidly deteriorate due to an abnormal, continuous overheating: in this case the damaged parts will not be covered by warranty.

**IN THE EVENT OF A FIRE IN THE CHIMNEY CLOSE ALL THE AIR PASSAGES AND CALL THE FIRE BRIGADE IMMEDIATELY**

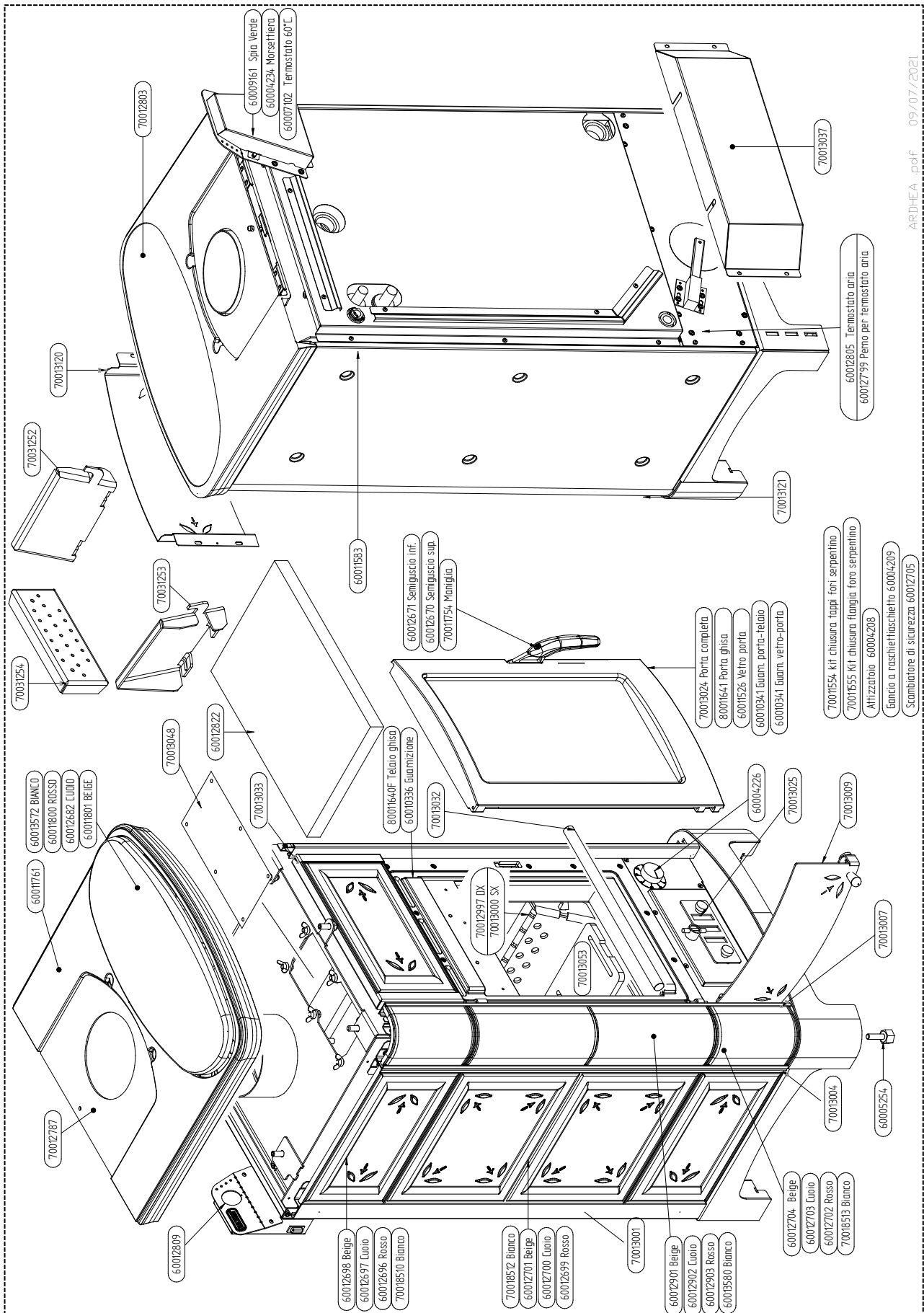
**10 - PROBLEMS, CAUSES AND SOLUTIONS**

PROBLEM	CAUSE	SOLUTION
Difficulty in lighting the cooker.	Blocked grate.	Clean the grate.
	Moist wood or too thick.	Use smaller sized and more seasoned wood.
	Poor draught.	Clean the ash pan. Thoroughly clean the flue gas path and the flue outlet Check the flue pipe: <ul style="list-style-type: none"> <li>• for constrictions</li> <li>• too many curves</li> <li>• bad insulation</li> <li>• section too small</li> </ul>
Smoke in the room. Difficulty maintaining the fire. The oven is not heating properly. Flame insensitive to draft variations. Puffs while operating.	Poor draught.	Clean the ash pan. Thoroughly clean the flue gas path. Clean (or have someone clean) the flue. Check the flue pipe: <ul style="list-style-type: none"> <li>• for constrictions</li> <li>• too many curves</li> <li>• bad insulation</li> <li>• section too small</li> </ul>
	No air in the room.	Create an adequate opening for the air.
	Moist wood or too thick.	Use smaller sized and more seasoned wood.
The fuel is burning too quickly, uncontrolled combustion.	Excessive draught.	Reduce draught of the flue outlet by installing a suitable device (e.g. draught regulator).
The oven thermometer is no longer accurate or has yellowed. The handles have warped. Broken components inside the combustion chamber.	Excessive consumption of wood, more than the amount indicated in this manual.	Contact a service centre to restore the appliance for a fee then use the appliance as instructed in this manual and comply with all the supplied instructions.
	Incorrect use of the appliance.	
	No or poor cleaning of the appliance.	
Tendency to generate condensation (presence of humidity /water in the ash-pan compartment and under the product). The temperature of the oven is not rising.	Poor draft	Check the flue outlet
	The system is not absorbing sufficient heat.	Open all the zones of the system, load less wood or install a puffer.
The temperature of the oven is not rising.	Excessive draught.	Reduce draught of the flue outlet by installing a suitable device (e.g. draught regulator).

**IF THE RECOMMENDED REMEDIES DO NOT SOLVE THE PROBLEM CONTACT A QUALIFIED TECHNICAL ASSISTANCE SERVICE.**

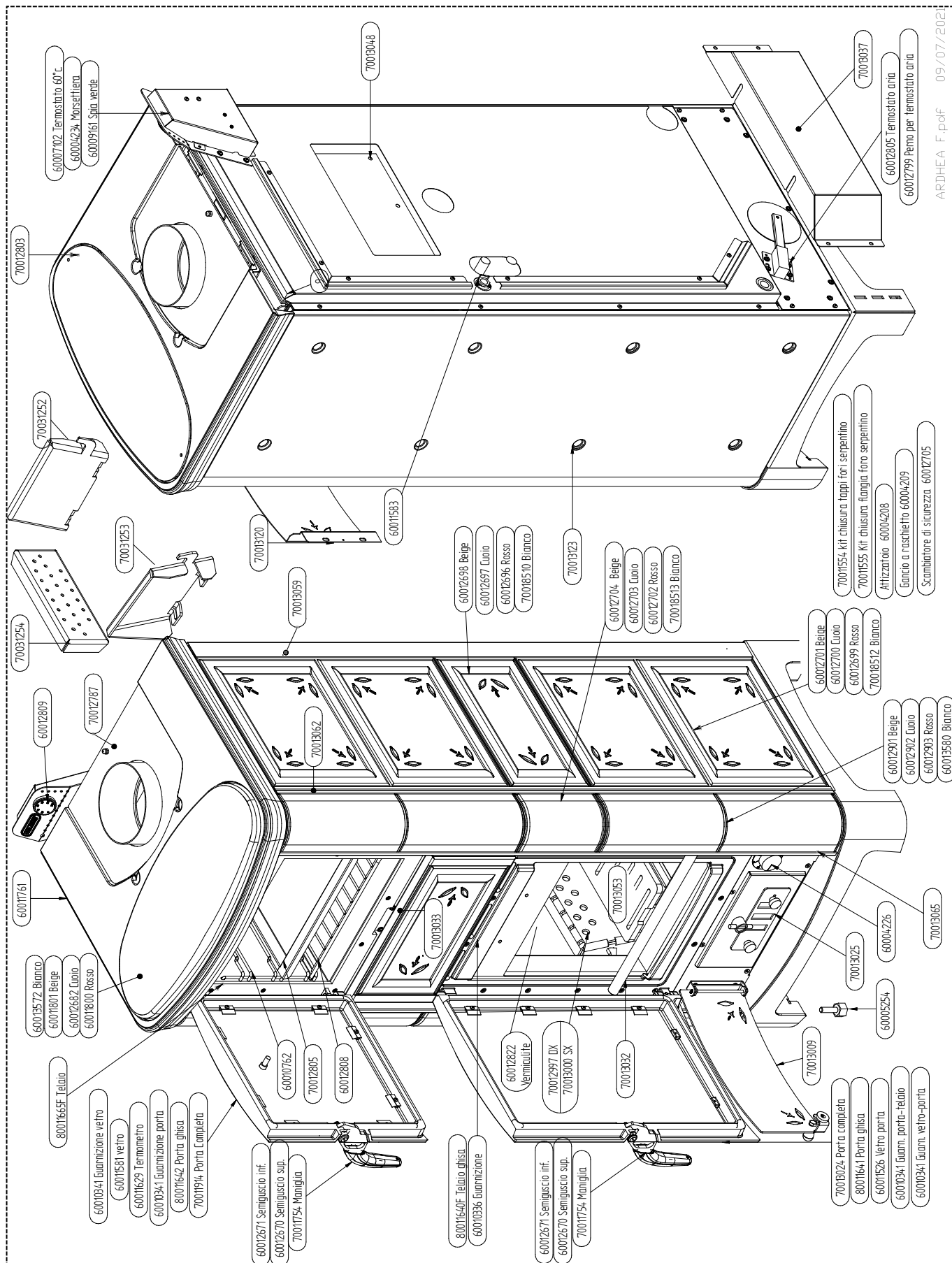
11 - SPARE PARTS

ARDHEA EVO5



ARDHEA.pdf 09/07/2021

**ARDHEA-F EVO5**



ARDHEA\_F.pdf 09/07/2021

<b>LEGENDA</b>	<b>KEY</b>
<b>ARDHEA EVO5</b>	<b>ARDHEA EVO5</b>
BIANCO	WHITE
ROSSO	RED
CUOIO	LEATHER
BEIGE	BEIGE
Telaio ghisa	Cast iron frame
Guarnizione	Gasket
Semiguschio inf.	Bottom half shell
Semiguscio sup.	Top half shell
Maniglia	Handle
DX	RH
SX	LH
Porta completa	Complete door
Porta ghisa	Cast door
Vetro porta	Door glass
Guarn. Porta-telaio	Door-frame gasket
Guarn. Vetro-porta	Glass-door gasket
Kit chiusura tappi fori serpentino	Coil hole plug closing kit
Kit chiusura flangia foro serpentino	Coil hole flange closing kit
Attizzatoio	Riddling tool
Gancio a raschietto	Scraper hook
Scambiatore di sicurezza	Safety heat exchanger
Spia verde	Green indicator light
Morsettiera	Terminal block
Termostato 60°C	Thermostat 60°C
Termostato aria	Air thermostat
Perno per termostato aria	Pin for air thermostat
<b>ARDHEA-F EVO5</b>	<b>ARDHEA-F EVO5</b>
BIANCO	WHITE
ROSSO	RED
CUOIO	LEATHER
BEIGE	BEIGE
Telaio	Frame
Guarnizione vetro	Glass gasket
Vetro	Glass
Termometro	Thermometer
Guarnizione porta	Door gasket
Porta ghisa	Cast door
Porta completa	Complete door
Semiguscio inf.	Bottom half shell
Semiguscio sup.	Top half shell
Maniglia	Handle
Telaio ghisa	Cast iron frame
Guarnizione	Gasket
Vermiculite	Vermiculite
DX	RH
SX	LH
Porta completa	Complete door
Porta ghisa	Cast door
Vetro porta	Door glass
Guarn. Porta-telaio	Door-frame gasket
Guarn. Vetro-porta	Glass-door gasket
Termostato 60°C	Thermostat 60°C
Morsettiera	Terminal block
Spia verde	Green indicator light
Kit chiusura tappi fori serpentino	Coil hole plug closing kit
Kit chiusura flangia foro serpentino	Coil hole flange closing kit
Attizzatoio	Riddling tool
Gancio a raschietto	Scraper hook
Scambiatore di sicurezza	Safety heat exchanger
Termostato aria	Air thermostat
Perno per termostato aria	Pin for air thermostat



**THERMOROSSI**   
FireLoes

THERMOROSSI S.p.A.  
Via Grumolo, 4 (Z.I.) 36011 Arsiero (VI) - ITALY  
Fax 0445.741657 - [www.thermorossi.com](http://www.thermorossi.com) - [info@thermorossi.it](mailto:info@thermorossi.it)